

MAGELLAN DESIGNS

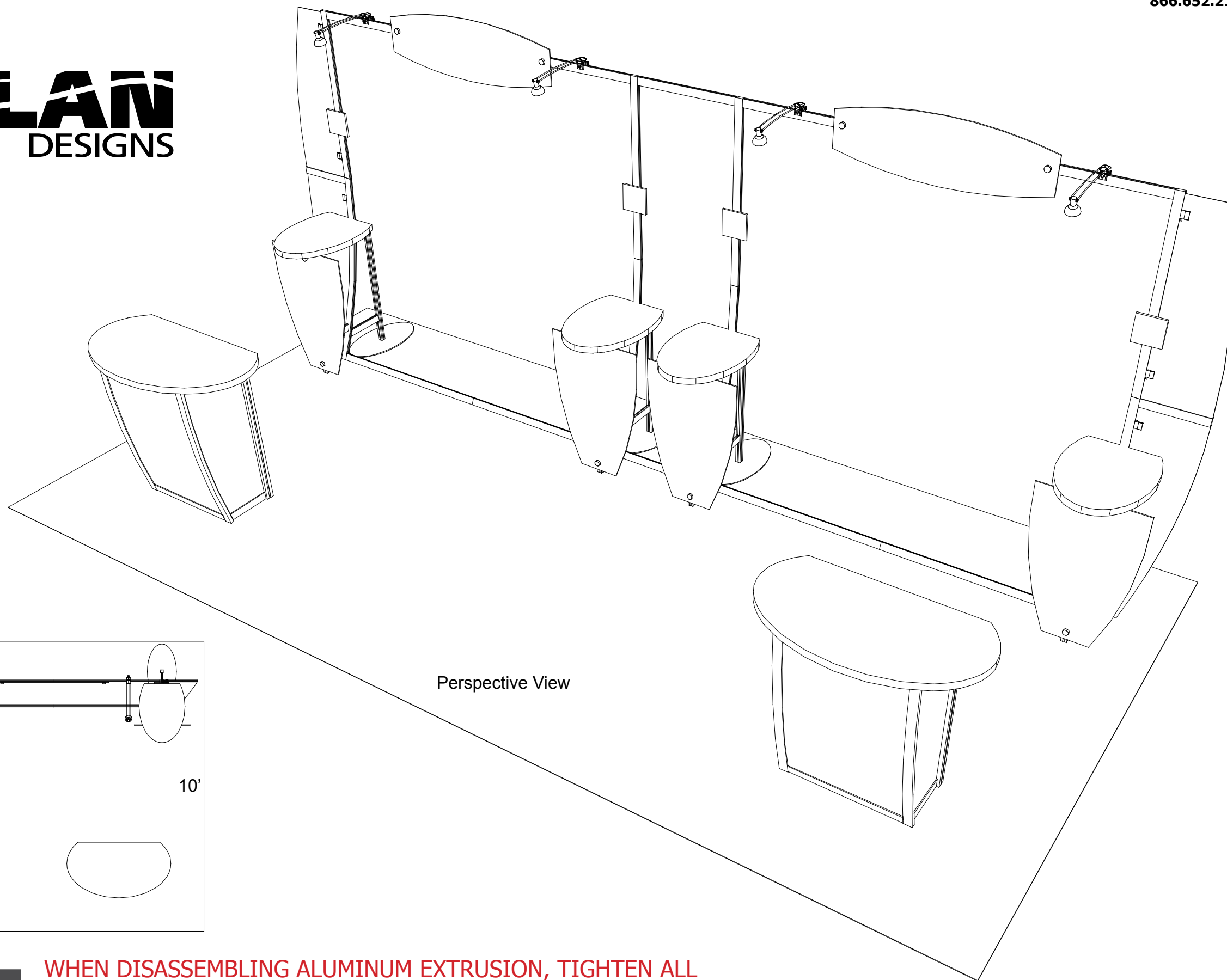

Perspective View

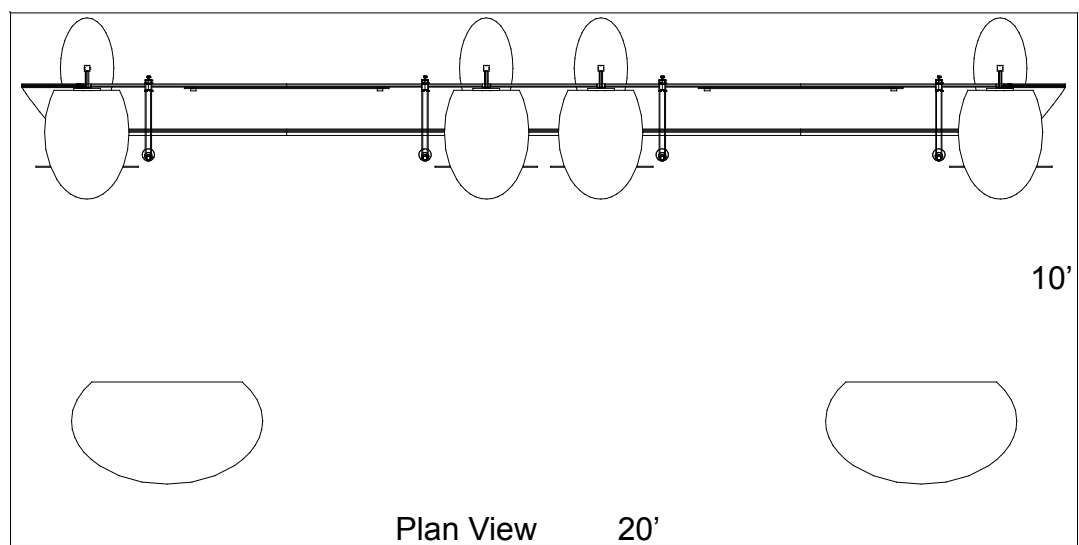

Plan View 20'

WHEN DISASSEMBLING ALUMINUM EXTRUSION, TIGHTEN ALL SETSCREWS AND LOCKS TO PREVENT LOSS DURING SHIPPING



MAGELLAN DESIGNS

Using Your Set-up Instructions:

The Visionary Designs Set-up Instructions for Magellan displays are created specifically for your configuration. They are laid out sequentially, including an exploded view of the entire display and a logical series of detailed steps for assembly. We encourage you to study the instructions **before** attempting to assemble your exhibit.

THIS IS VERY IMPORTANT!

Each page reminds you to tighten the setscrews after disassembling your exhibit to prevent loss of the locks and setscrews (see below in red).

Cleaning & Packing Your Display:

- 1) Use care when cleaning aluminum extrusions or acrylic inserts. Use only non-abrasive cleaners.
- 2) When cleaning laminate inserts or counter tops, use mild cleansers and a soft material such as cotton.
- 3) Keep all display components away from extreme heat and long exposure to sunlight to avoid warping and fading.
- 4) Retain all packing materials. It will make re-packing much easier and will reduce the likelihood of shipping damage.

Hex Key Tool



Most visionary design exhibits can be assembled with the supplied Hex Key Tool. Occasionally, a flat head screwdriver may be required.

Typical Connection



Detail A: Most horizontal extrusion connections have a patented expandable lock. This lock inserts into the groove of an opposing extrusion. Tightening the lock with the Hex Key Tool expands the lock and creates a strong positive connection.

Typical Connection



Numbered Label

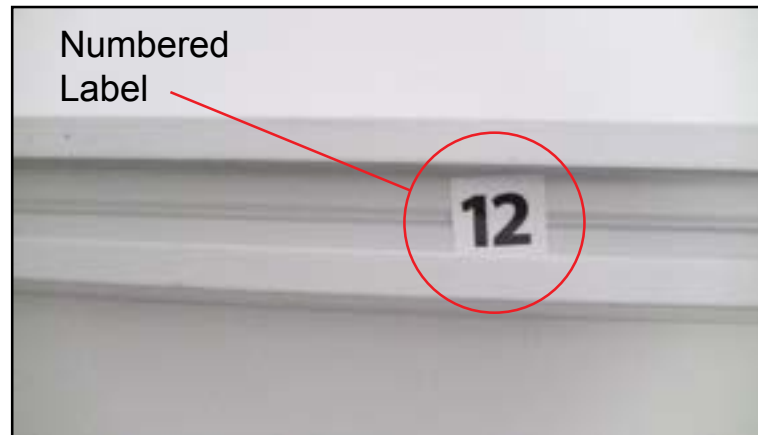

Detail B: Each extrusion contains a numbered label that corresponds to set-up instructions. The label is located within a groove of the extrusion (when possible). Visionary Design labels contain Black numbers unless otherwise specified.

Horizontal Connection



Detail C: A rectangular connection bar with plastic T Knobs is inserted between two horizontal extrusions joined end-to-end. Turn the knobs clockwise to tighten. Do Not Overtighten.

WHEN DISASSEMBLING ALUMINUM EXTRUSION, TIGHTEN ALL SETSCREWS AND LOCKS TO PREVENT LOSS DURING SHIPPING

Steps:

- 1) Attach oval base plates [1] to verticals [2] using bolts as shown.
- 2) Attach horizontals [3,4] to verticals [2].
- 3) Attach upper verticals to lower curved verticals.
- 4) Connect horizontals [13A,14A] together.
- 5) Attach vertical assemblies to horizontals [3,4].
- 6) Attach horizontal assemblies between vertical assemblies.
- 7) Attach horizontals [17A,18A] between to assembled sections.
- 8) Velcro attach graphics to back of assembled backwall.

* = Connector A

* = Connector B

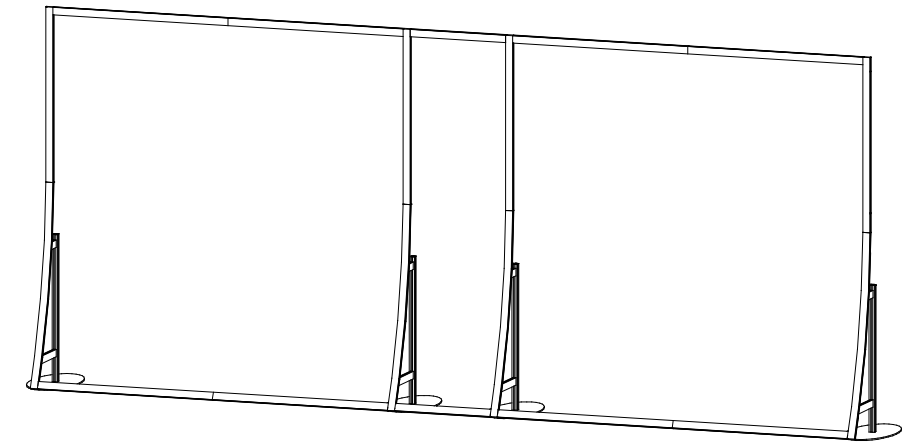

When assembled

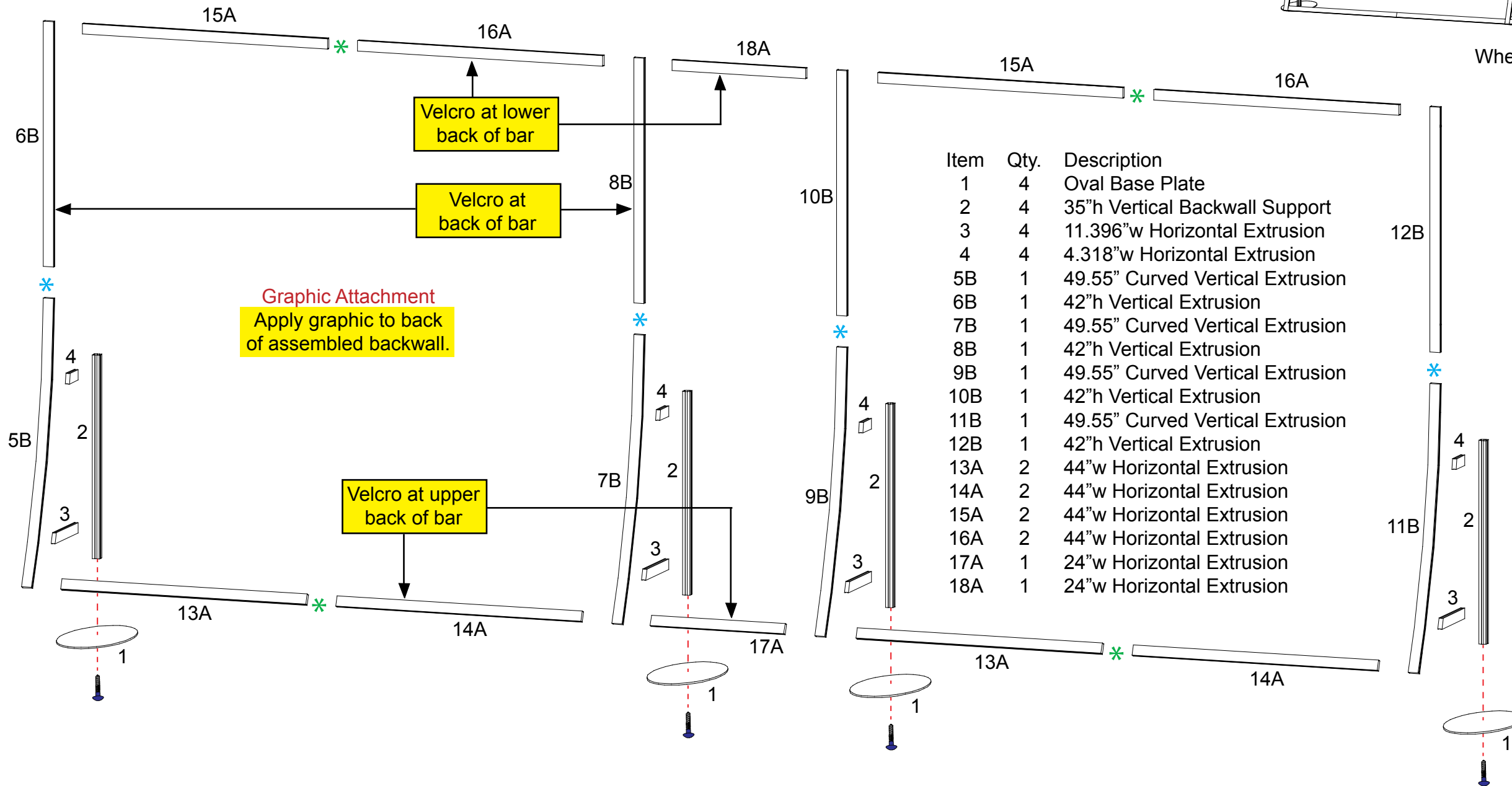

Item	Qty.	Description
1	4	Oval Base Plate
2	4	35" h Vertical Backwall Support
3	4	11.396" w Horizontal Extrusion
4	4	4.318" w Horizontal Extrusion
5B	1	49.55" Curved Vertical Extrusion
6B	1	42" h Vertical Extrusion
7B	1	49.55" Curved Vertical Extrusion
8B	1	42" h Vertical Extrusion
9B	1	49.55" Curved Vertical Extrusion
10B	1	42" h Vertical Extrusion
11B	1	49.55" Curved Vertical Extrusion
12B	1	42" h Vertical Extrusion
13A	2	44" w Horizontal Extrusion
14A	2	44" w Horizontal Extrusion
15A	2	44" w Horizontal Extrusion
16A	2	44" w Horizontal Extrusion
17A	1	24" w Horizontal Extrusion
18A	1	24" w Horizontal Extrusion

WHEN DISASSEMBLING ALUMINUM EXTRUSION, TIGHTEN ALL SETSCREWS AND LOCKS TO PREVENT LOSS DURING SHIPPING

866.652.2100

Item	Qty.	Description
19B	4	37.5"h Vertical Extrusion
19a	4	Flange Plate
20	4	9.3552"w Horizontal Extrusion
21	4	15.7689"w Horizontal Extrusion

Counter Top Attachment

Insert screws located on underside of counter into holes on flange plate and secure with wing nuts.



Wing Nut

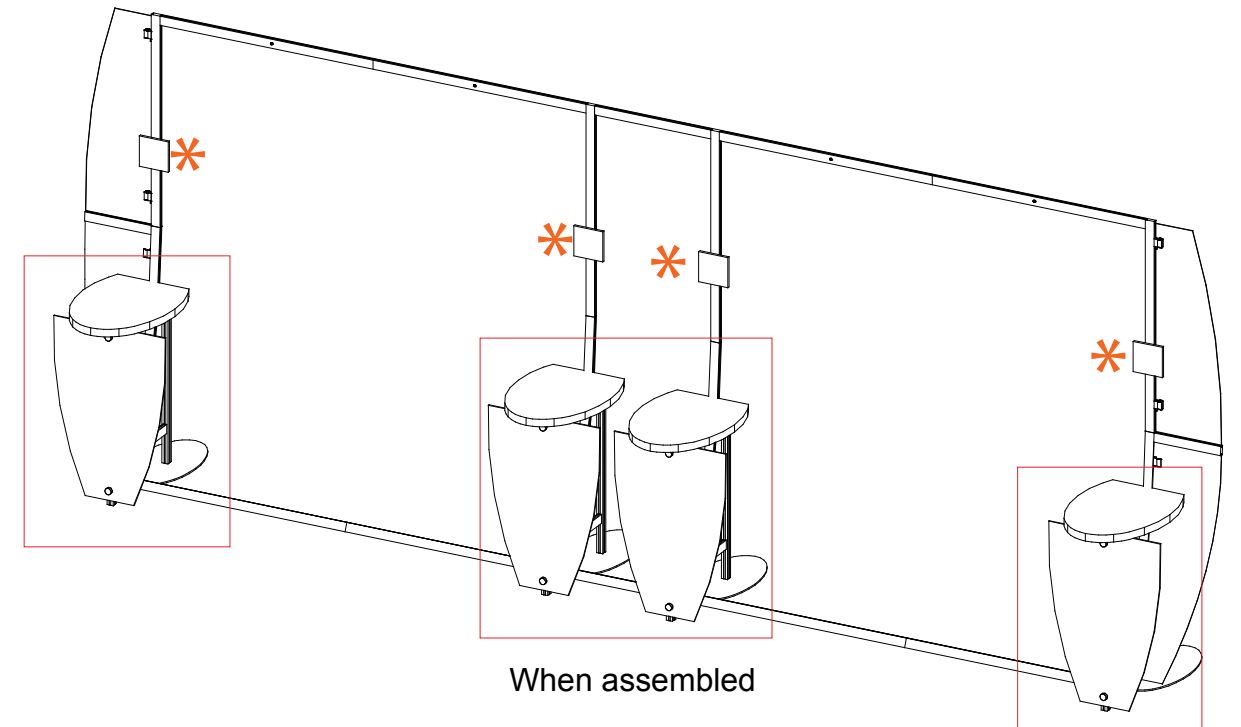
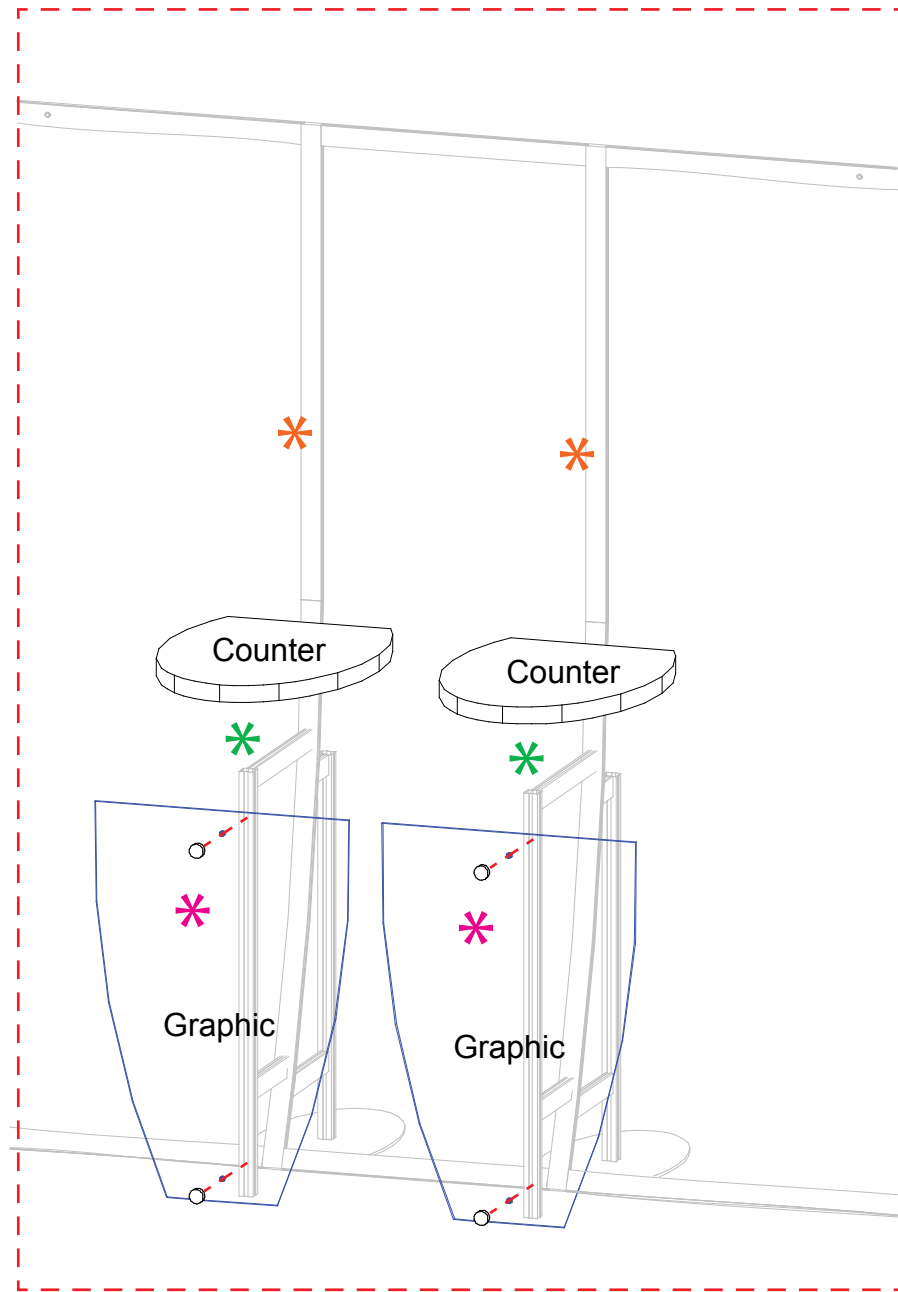
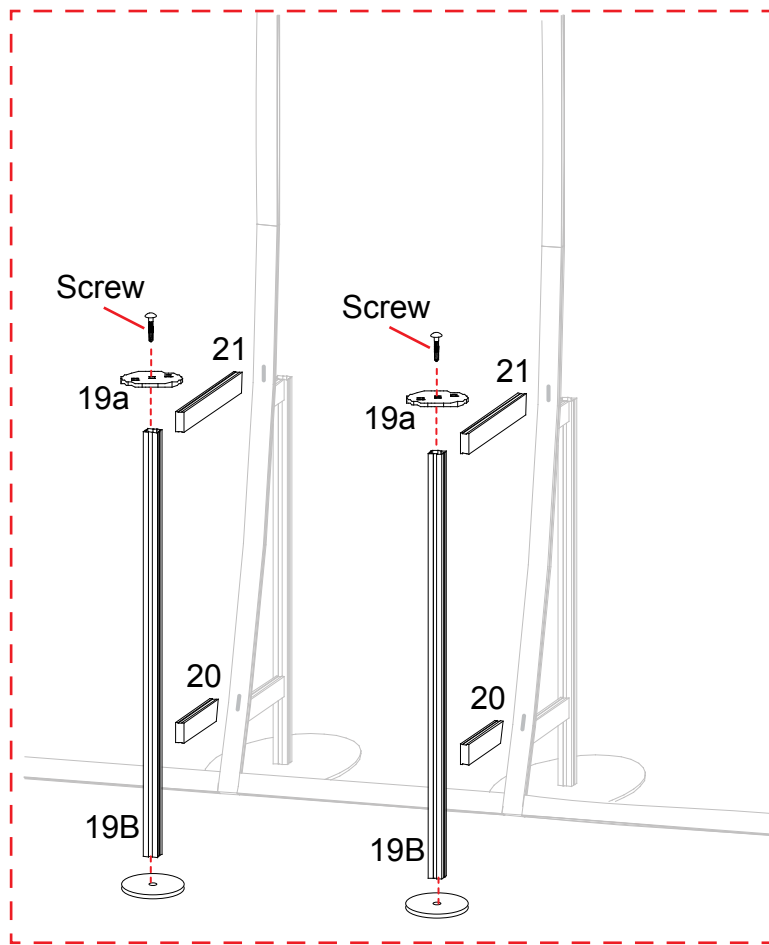

Graphic to Post Attachment

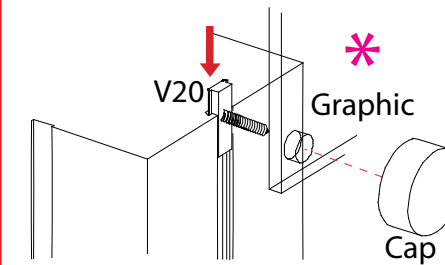

Slide connector with stud into groove of extrusion and twist to secure in place. Attach graphic with cap as shown.

Monitor Mount Attachment

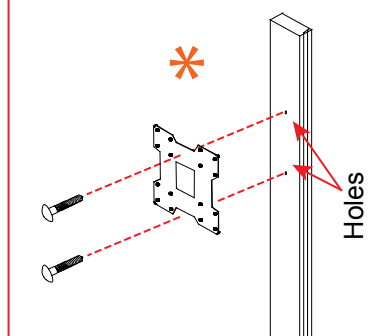

Attach monitor mount plate to vertical using setscrews provided.

Steps:

- 1) Attach horizontals [20-21] between verticals [19B] and assembled backwall.
- 2) Attach flange plates [19a] atop verticals [19B] using bolts as shown.
- 3) Place counter atop supports and secure in place as shown. Refer to detail.
- 4) Attach graphic to verticals [19B] using caps. Refer to detail.
- 5) Attach monitor mounts to assembled backwall. Refer to detail.

WHEN DISASSEMBLING ALUMINUM EXTRUSION, TIGHTEN ALL SETSCREWS AND LOCKS TO PREVENT LOSS DURING SHIPPING

866.652.2100

- Steps:
- 1) Attach graphic header to upper horizontals.
Refer to *Graphic Header Attachment* detail.
 - 2) Attach lights atop backwall.
Refer to *Light Connection* detail.

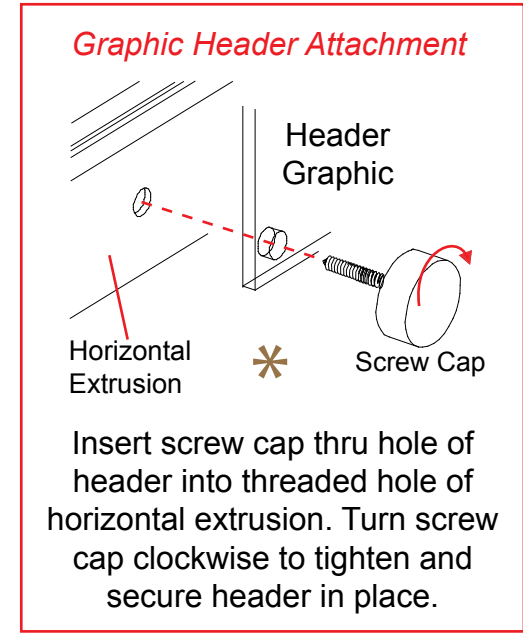
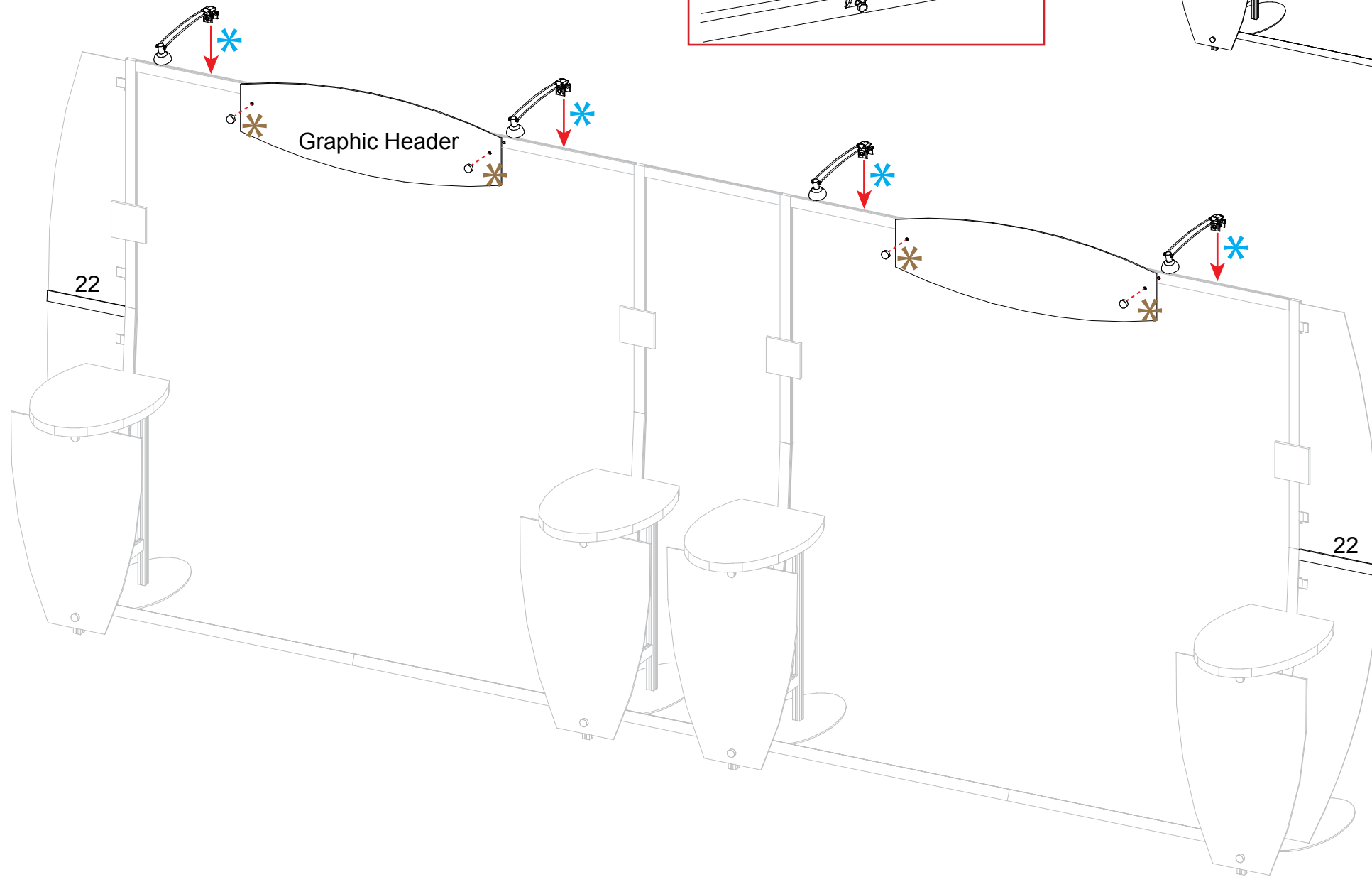
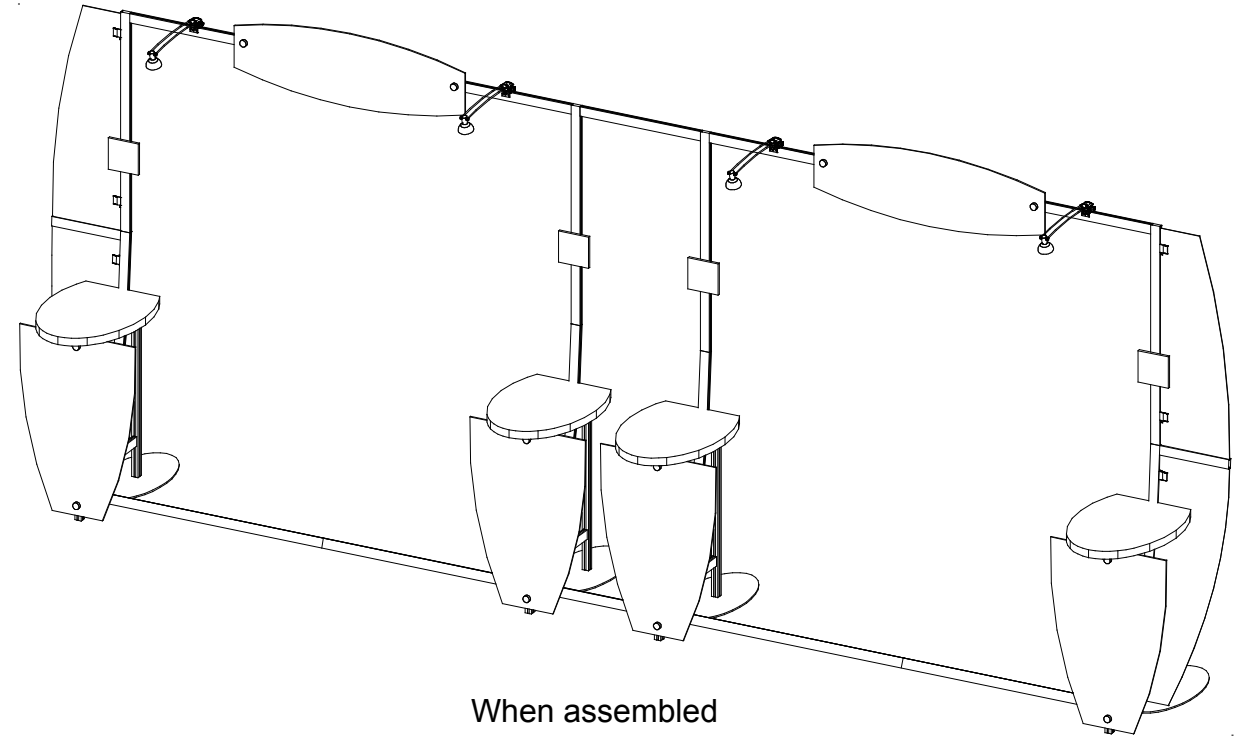
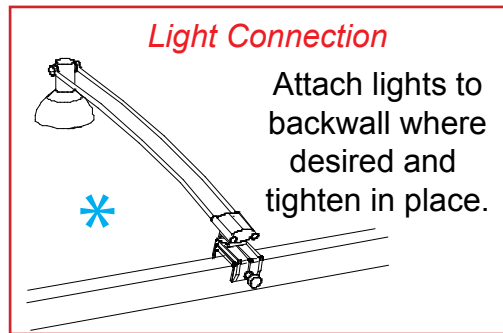

WHEN DISASSEMBLING ALUMINUM EXTRUSION, TIGHTEN ALL SETSCREWS AND LOCKS TO PREVENT LOSS DURING SHIPPING

Item	Qty.	Description
1	1	38"h Vertical Extrusion w/ Door Hinges
2	1	38"h Vertical Extrusion w/ Door Stopper
3	1	38.4565" Curved Extrusion w/ S10
4	1	38.4565" Curved Extrusion w/ S10
5	1	22.9803"w Horizontal Extrusion
6/6a	1/1	10.4062"w Horizontal Extrusion
7	1	23"w Horizontal Extrusion
8	1	22.9803"w Horizontal Extrusion
9/9a	1/1	15.0700"w Horizontal Extrusion
10	1	23"w Horizontal Extrusion

- Steps:
- 1) Attach lower horizontals between verticals.
 - 2) Attach door to vertical [1]. Refer to detail.
 - 3) Slide infills between verticals and rest atop lower horizontals as shown.
 - 4) Attach upper horizontals between verticals.
 - 5) Velcro attach shelf supports to inside of assembled pedestal.
 - 6) Place shelf atop shelf supports.
 - 7) Place counter atop assembled pedestal.

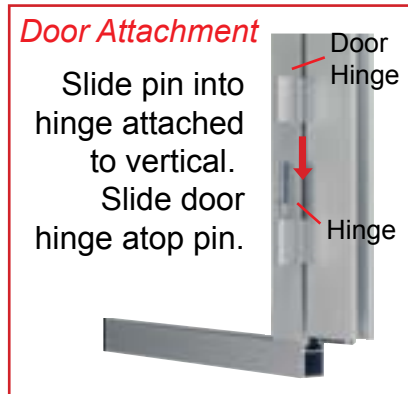

*** KEEP Left and Right pedestal wall assembly together when shipping ***

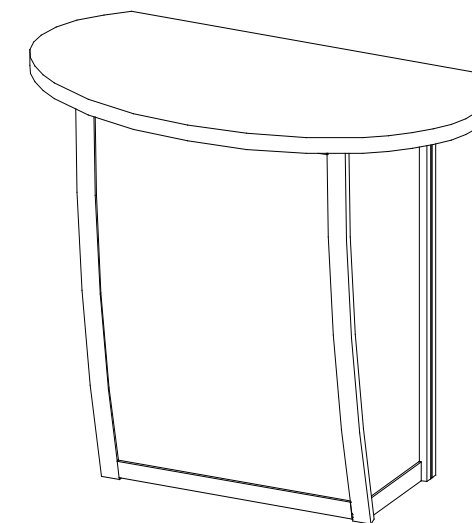

When assembled

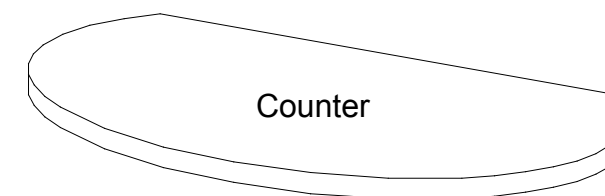
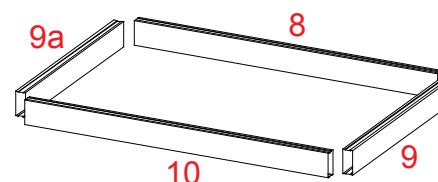

Counter

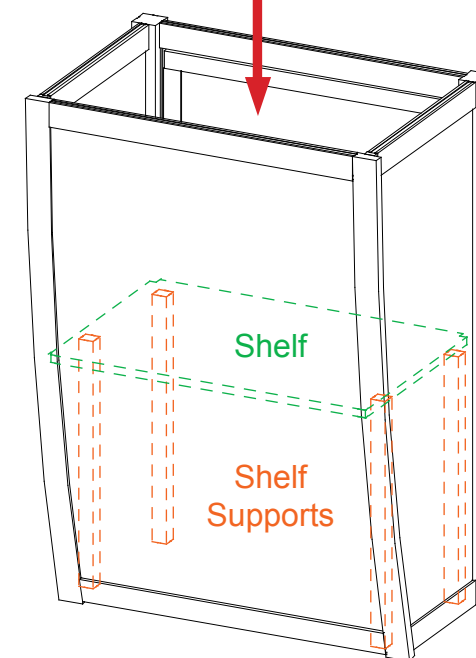
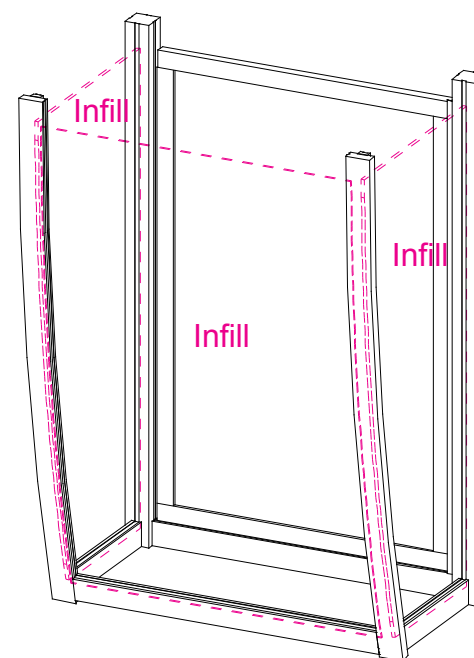
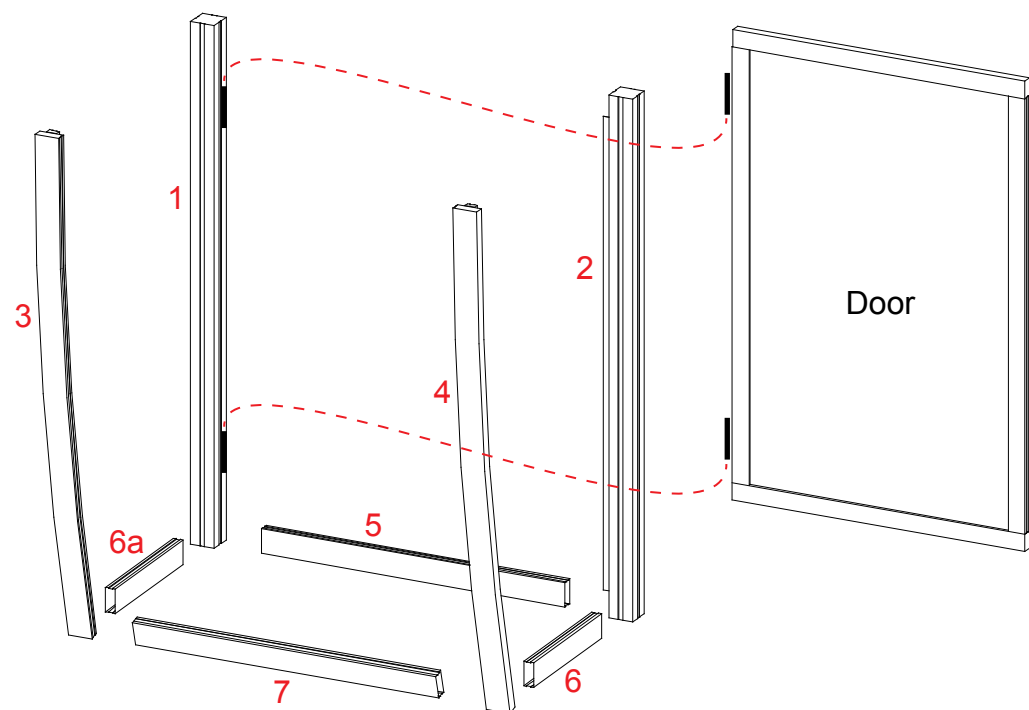

WHEN DISASSEMBLING ALUMINUM EXTRUSION, TIGHTEN ALL SETSCREWS AND LOCKS TO PREVENT LOSS DURING SHIPPING

Top View of Each Level

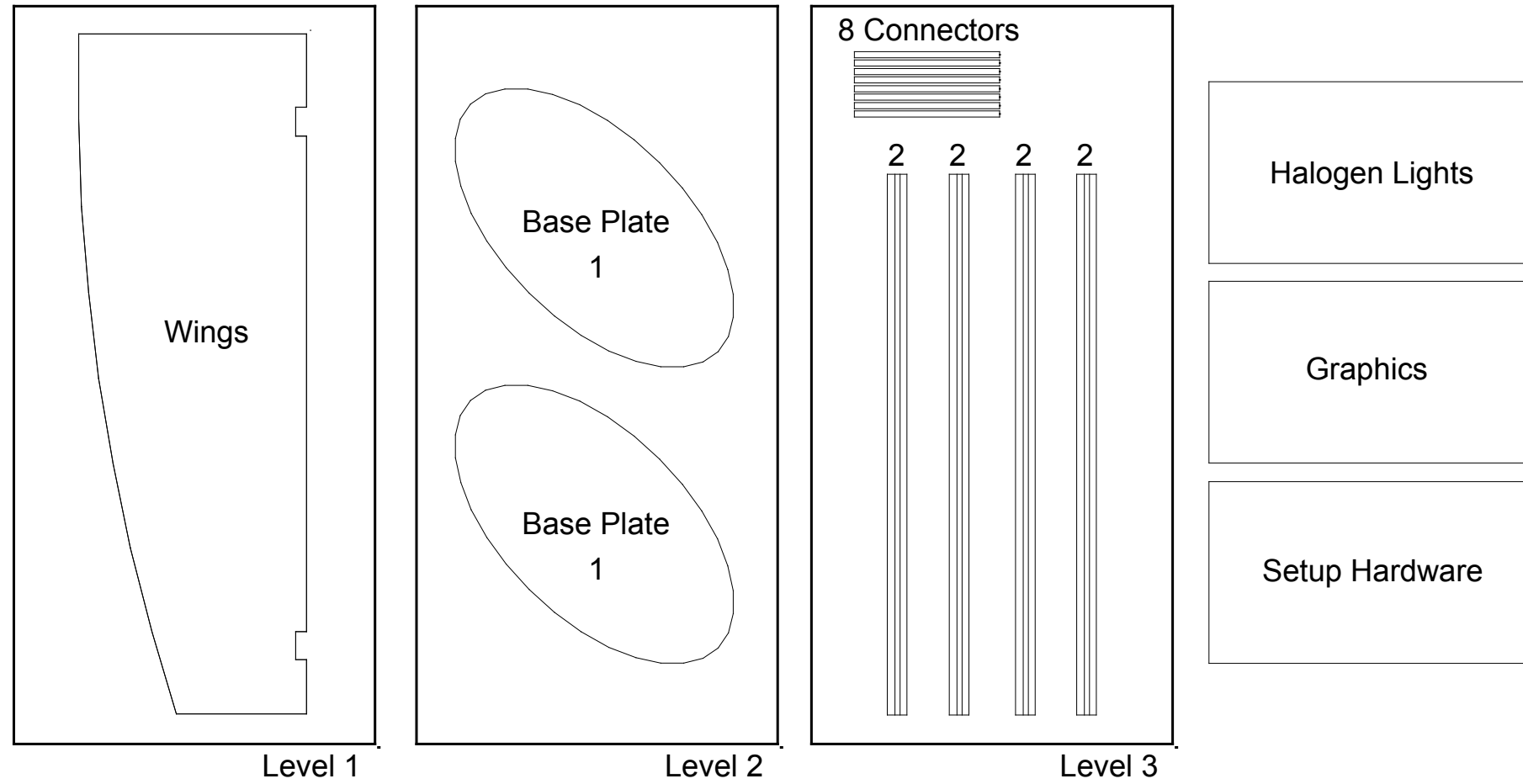

WHEN DISASSEMBLING ALUMINUM EXTRUSION, TIGHTEN ALL SETSCREWS AND LOCKS TO PREVENT LOSS DURING SHIPPING

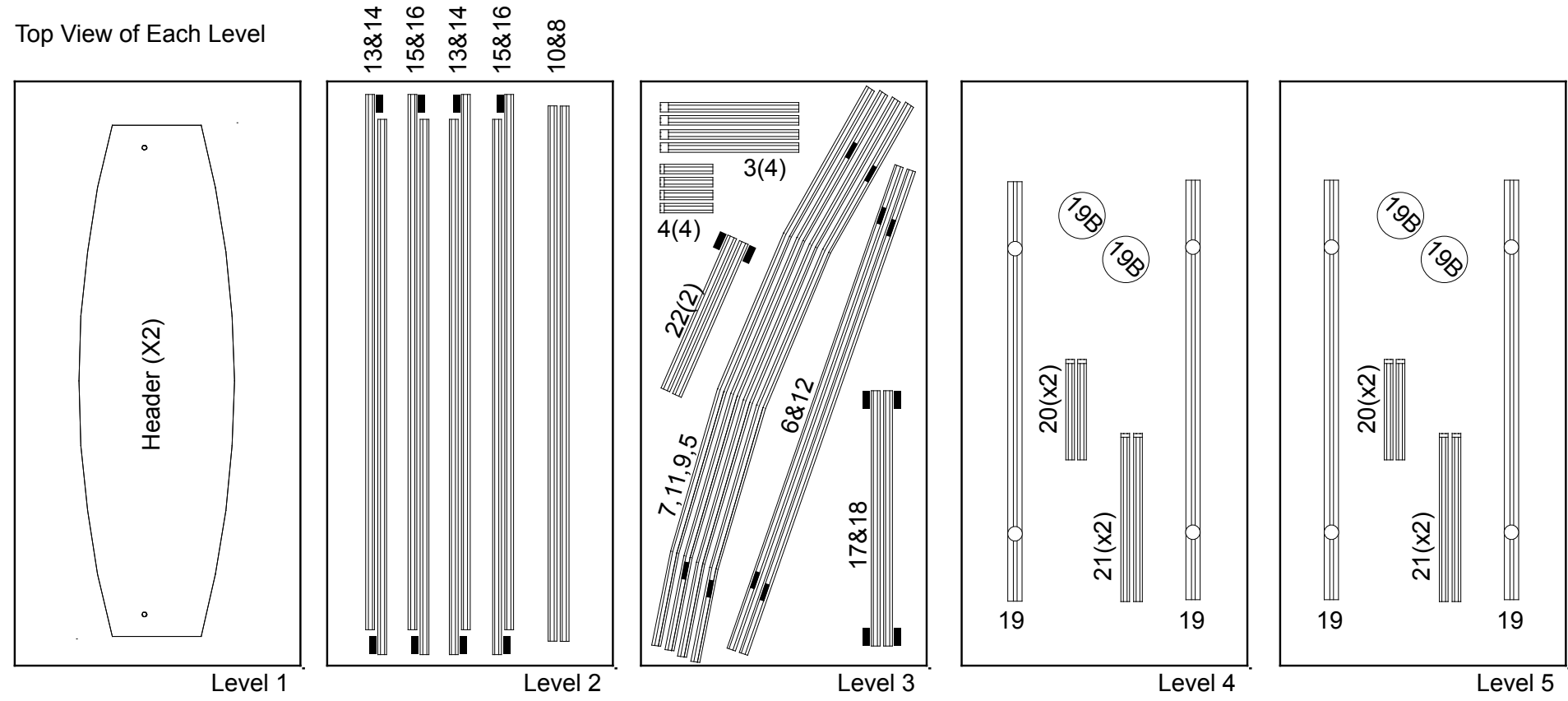

WHEN DISASSEMBLING ALUMINUM EXTRUSION, TIGHTEN ALL SETSCREWS AND LOCKS TO PREVENT LOSS DURING SHIPPING

Top View of Each Level

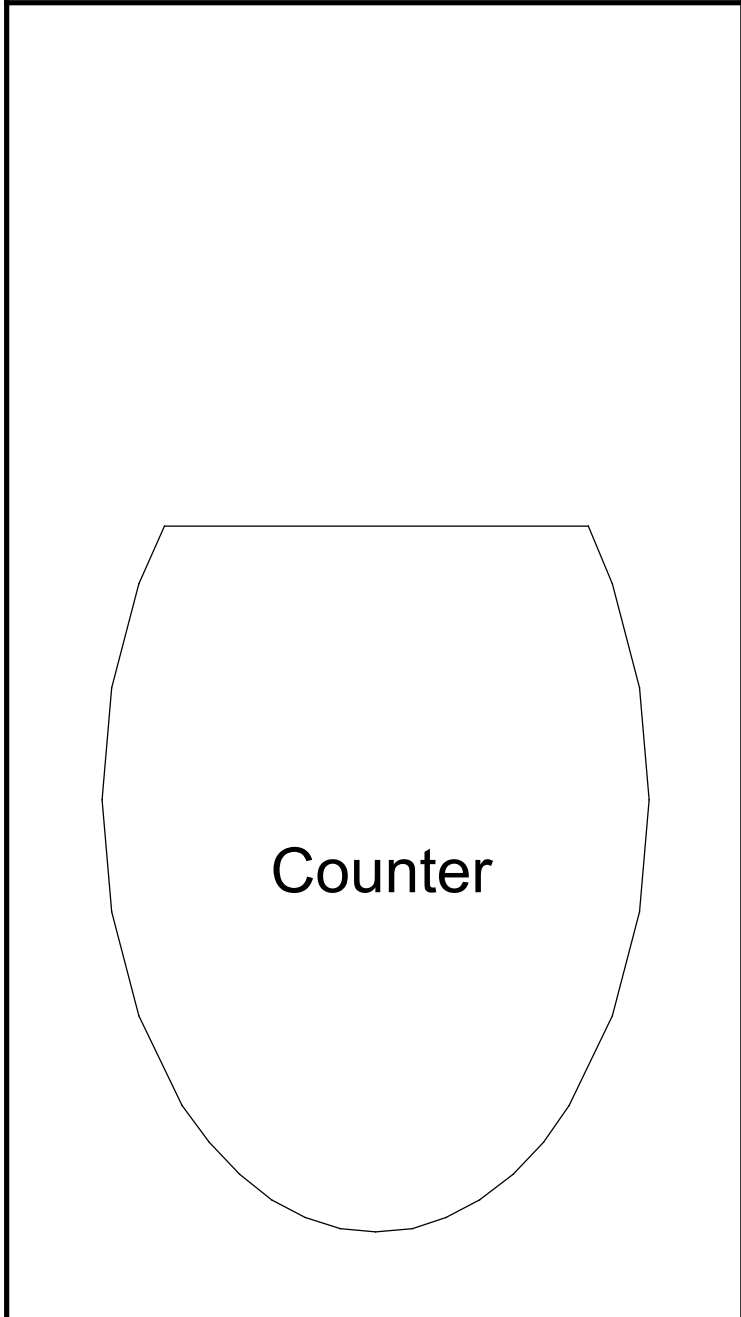
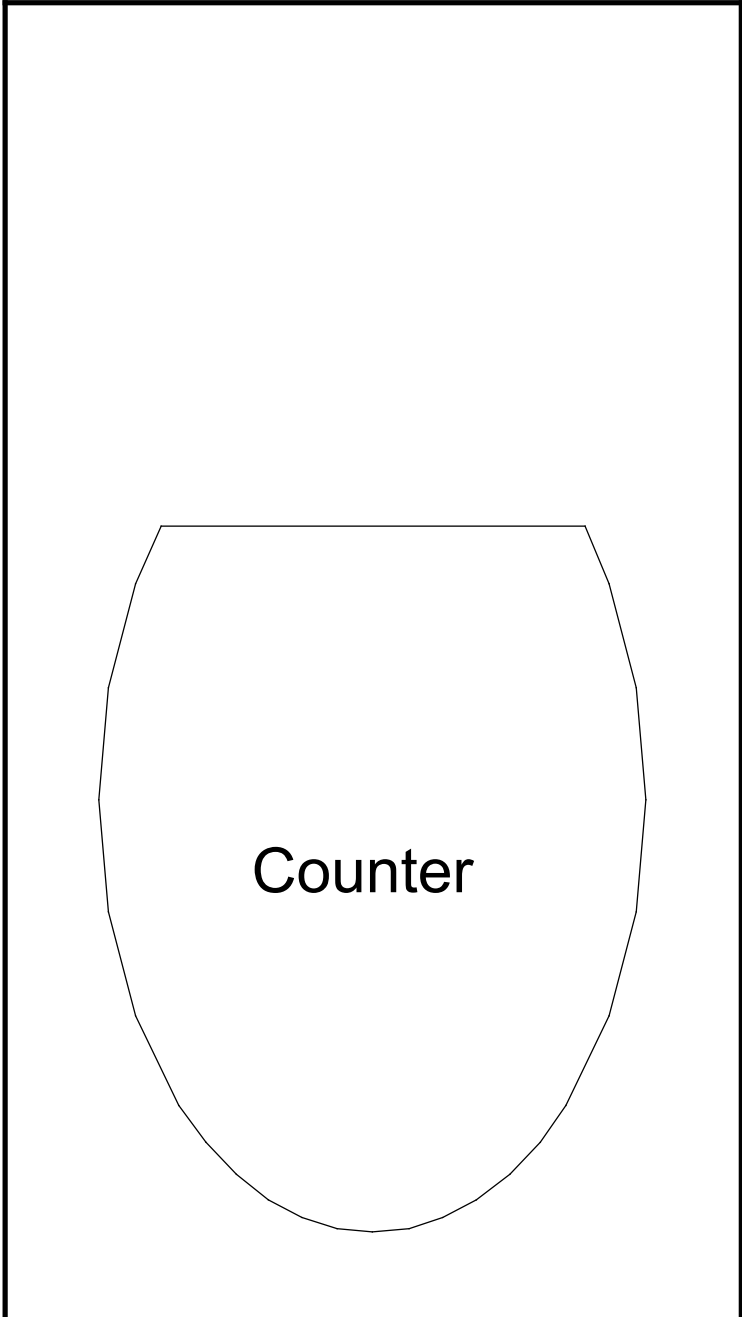
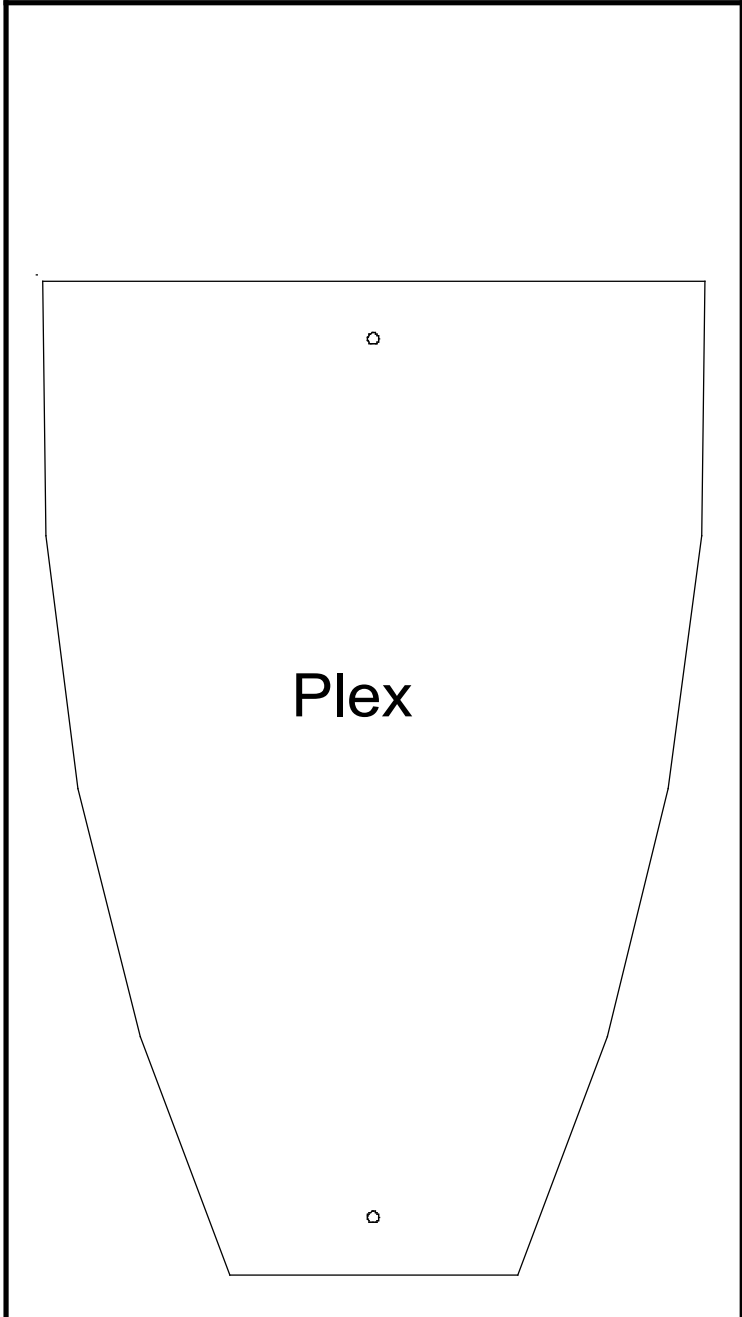

WHEN DISASSEMBLING ALUMINUM EXTRUSION, TIGHTEN ALL SETSCREWS AND LOCKS TO PREVENT LOSS DURING SHIPPING

Top View of Each Level

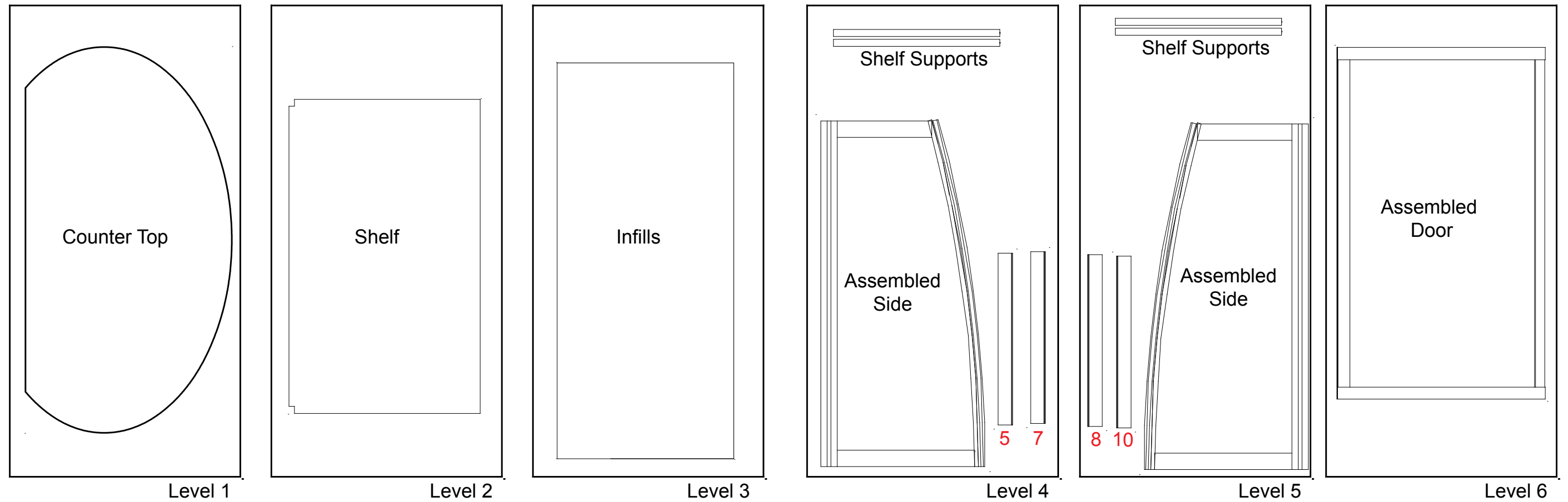

WHEN DISASSEMBLING ALUMINUM EXTRUSION, TIGHTEN ALL SETSCREWS AND LOCKS TO PREVENT LOSS DURING SHIPPING

Top View of Each Level

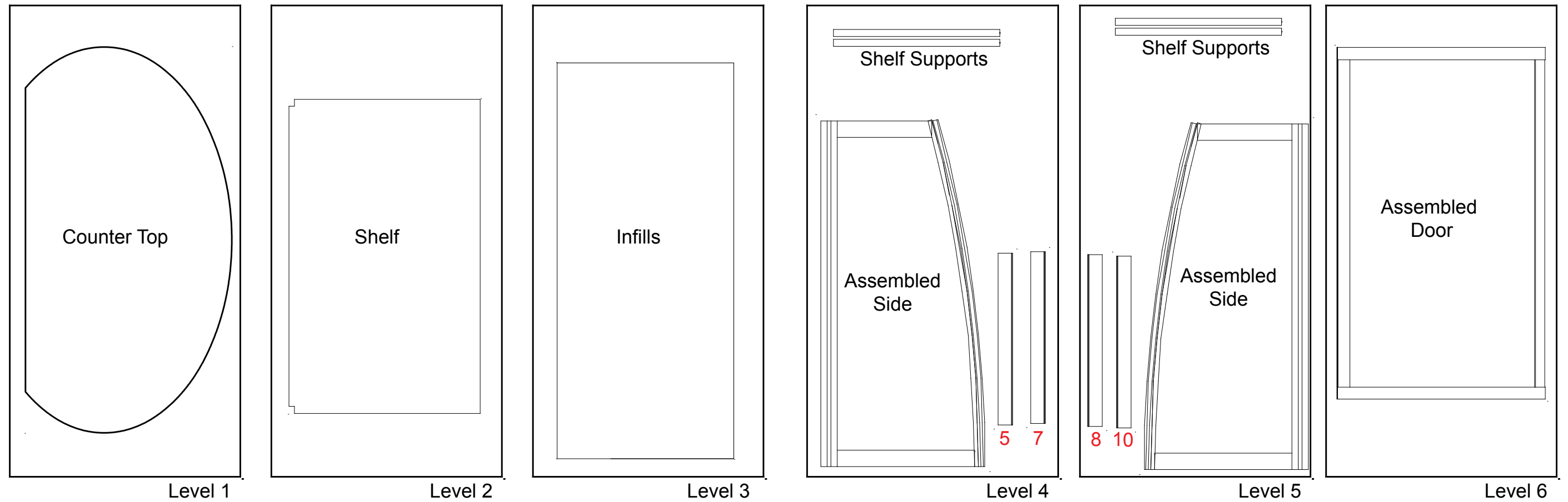

WHEN DISASSEMBLING ALUMINUM EXTRUSION, TIGHTEN ALL SETSCREWS AND LOCKS TO PREVENT LOSS DURING SHIPPING