

Plan View

10'

10'

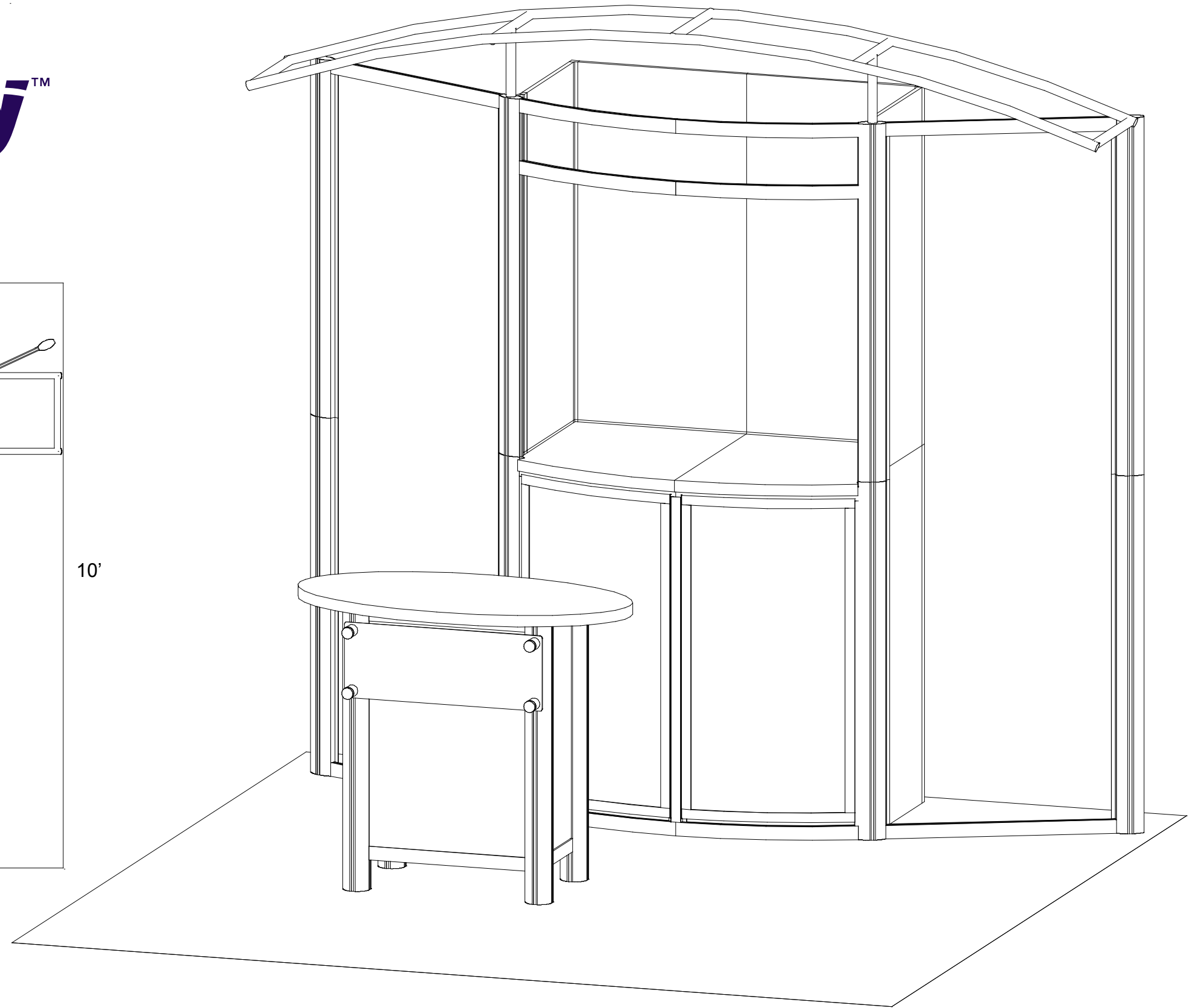

WHEN DISASSEMBLING ALUMINUM EXTRUSION, TIGHTEN ALL SETSCREWS AND LOCKS TO PREVENT LOSS DURING SHIPPING



visionary™ DESIGNS

Using Your Setup Instructions

The Visionary Designs Setup Instructions are created specifically for your configuration. They are laid out sequentially, including an exploded view of the entire display, and then a logical series of detailed steps to assemble the main structure and components. We encourage you to study the instructions **before** attempting to assemble your exhibit.

Each page reminds you to tighten the setscrews after disassembling your exhibit to prevent loss of the locks and setscrews (see below in RED). This is **VERY IMPORTANT**.

Cleaning and Packing Your Display

- 1) Use care when cleaning aluminum extrusion or acrylic inserts. Use only non-abrasive cleaners.
- 2) When cleaning laminate inserts or countertops, use mild cleansers and a soft material such as cotton.
- 3) Keep all display components away from extreme heat and long exposure to sunlight to avoid warping and fading.
- 4) Retain all packing material. It will make re-packing much easier and will reduce the likelihood of shipping damage.



The Tool

Most Visionary Designs exhibits can be assembled with the supplied Hex Key Tool. Occasionally, a flat head screwdriver may be required.



Typical Connection

Most horizontal extrusion connections have a patented expandable lock. This lock inserts into the groove of an opposing extrusion. Tightening the lock with the Hex Key Tool expands the lock and creates a strong positive connection.



Typical Connection (cont'd)

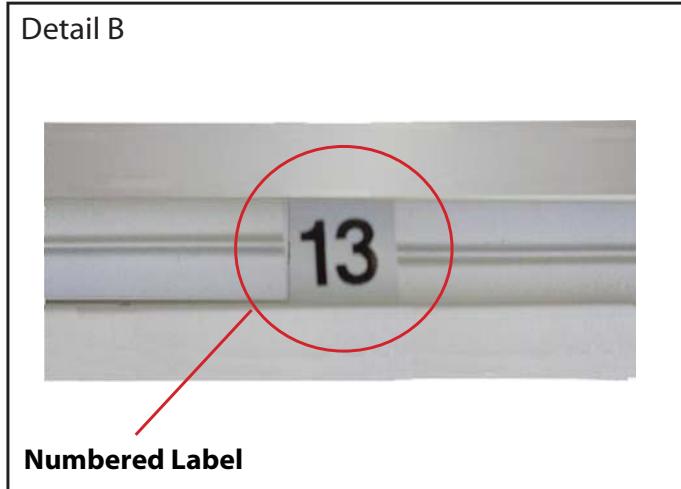

Detail B

Numbered Label

Each extrusion contains a numbered label which corresponds with setup instructions. The label is located within a groove of the extrusion (when possible). With Visionary Designs the labels contain Black numbers unless otherwise specified.



Detail C

Horizontal Inline Connection (remove only one setscrew)

Remove only (1) setscrew when disassembling. Replace setscrew in extrusion after assembling it. Before packing, replace setscrew in extrusion to avoid losing it.

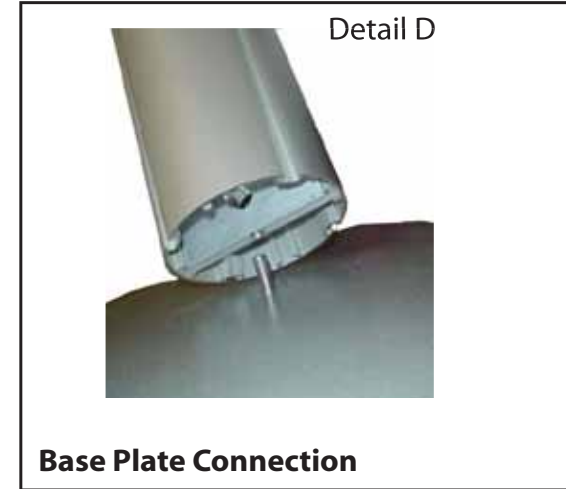

Detail D

Base Plate Connection

Attach base plate to round or square vertical extrusion using the bolt provided. Be careful not to strip the threads.

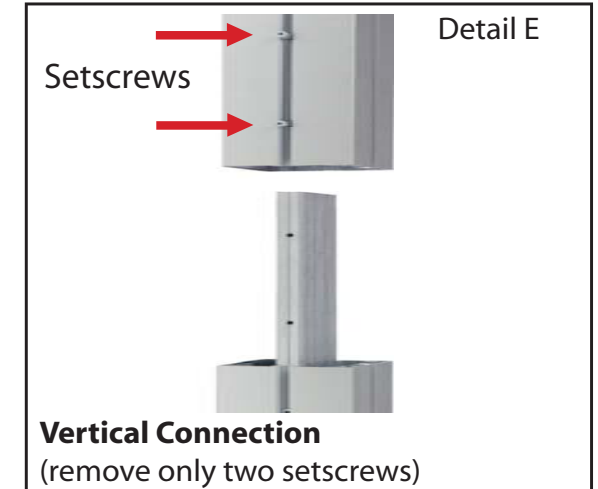

Detail E

Vertical Connection
(remove only two setscrews)

When vertical extrusions are packed in portable cases rather than crates or tubs, they must be broken down into smaller sections which then require assembly.

Remove only (2) setscrews when disassembling. Replace setscrews in extrusion after assembling it. Before packing, replace setscrews in extrusion to avoid losing them.

WHEN DISASSEMBLING ALUMINUM EXTRUSION, TIGHTEN ALL SETSCREWS AND LOCKS TO PREVENT LOSS DURING SHIPPING

| Item | Qty. | Description |
|------|------|--|
| 1/1A | 1/1 | 47.5"h Vertical Extrusion |
| 2/2A | 1/1 | 47.5"h Vertical Extrusion |
| 3 | 1 | 43.17"h Z45 Vertical Extrusion w/ door stops |
| 4 | 2/2 | 23.93"w Z45 Curved Horizontal Extrusions |
| 5 | 1 | 19"w x 47.5"h LT-Panel |
| 6 | 1 | 90° LT-Panel Connector |
| 7 | 1 | 23"w x 47.5"h LT-Panel |
| 8 | 1 | 23"w x 47.5"h LT-Panel |
| 9 | 1 | 90° LT-Panel Connector |
| 10 | 1 | 19"w x 47.5"h LT-Panel |

Steps:

- 1) Connect horizontal extrusions [4] together.
See **Horizontal Connection** detail.
Repeat step for horizontals [4A].
- 2) Attach assembled horizontals between verticals [1] & [2].
- 3) Connect vertical extrusion [3] between horizontal extrusion assemblies [4] & [4A].
NOTE: Connect at seam of assembled extrusions.
- 4) Connect LT-Panels and LT-Connectors in numerical order. Refer to General Information.
- 5) Attach vertical [1A] to vertical [1].
See **Vertical Connector** detail.
Repeat step of vertical [2A].

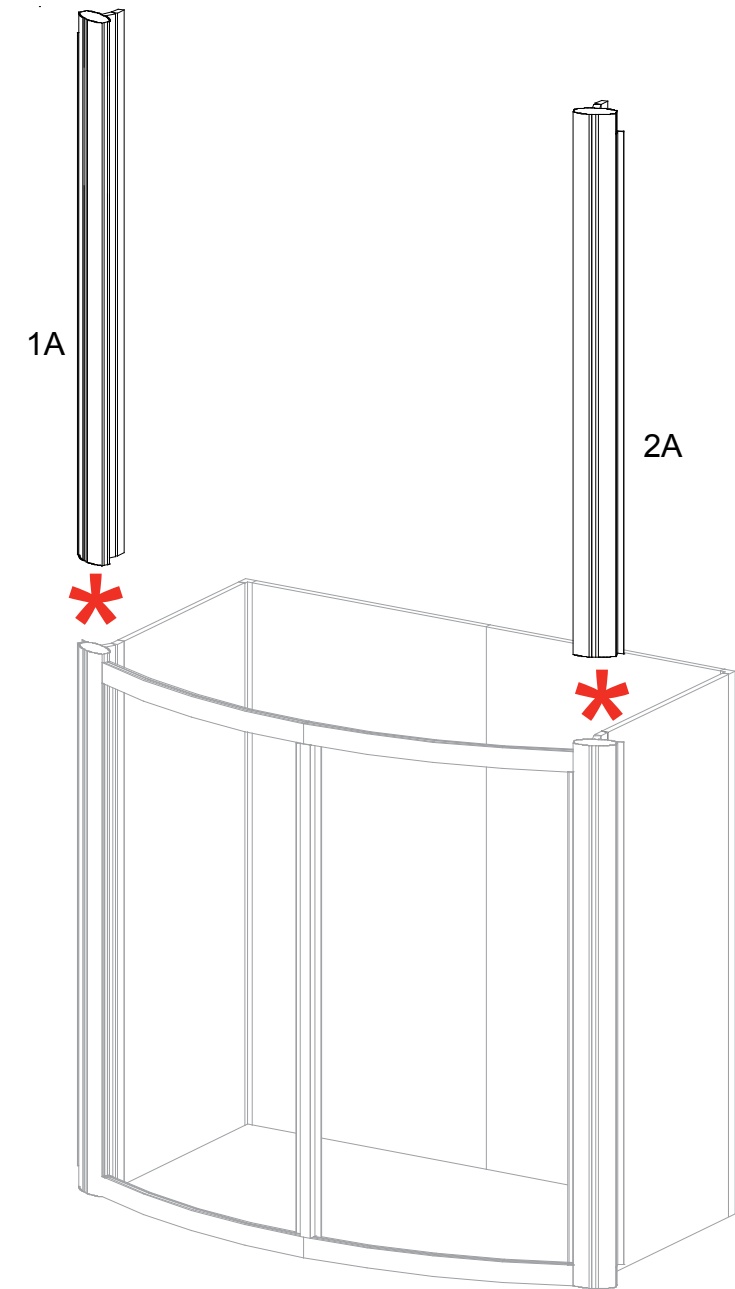
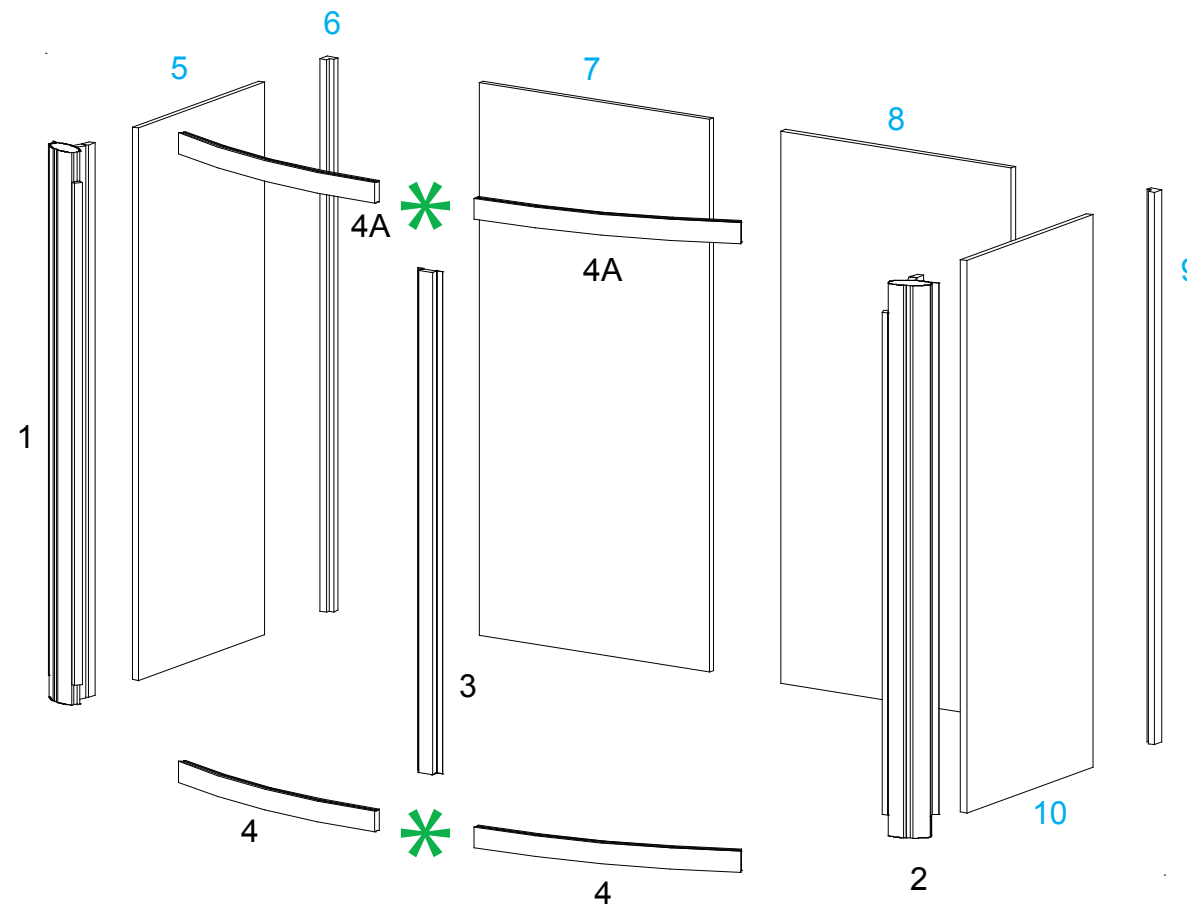
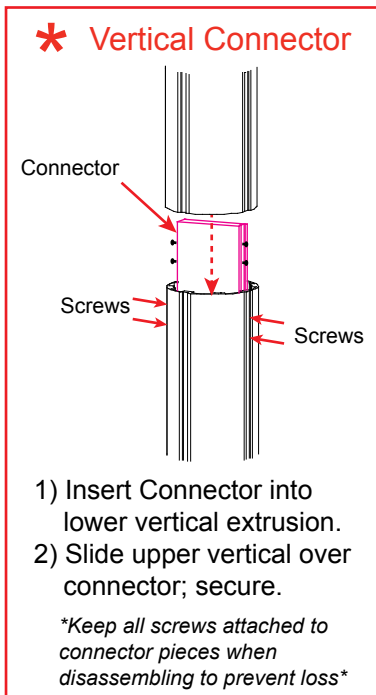
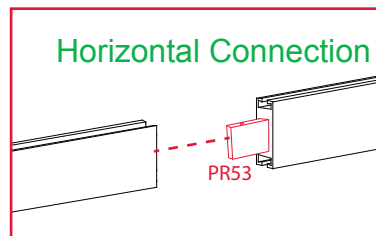

WHEN DISASSEMBLING ALUMINUM EXTRUSION, TIGHTEN ALL SETSCREWS AND LOCKS TO PREVENT LOSS DURING SHIPPING

866.652.2100

| Item | Qty. | Description |
|-------|------|--|
| 4C/4D | 2/2 | 23.93"w Z45 Curved Horizontal Extrusions |
| 5 | 1 | 19"w x 47.5"h LT-Panel |
| 6 | 1 | 90° LT-Panel Connector |
| 7 | 1 | 23"w x 47.5"h LT-Panel |
| 8 | 1 | 23"w x 47.5"h LT-Panel |
| 9 | 1 | 90° LT-Panel Connector |
| 10 | 1 | 19"w x 47.5"h LT-Panel |

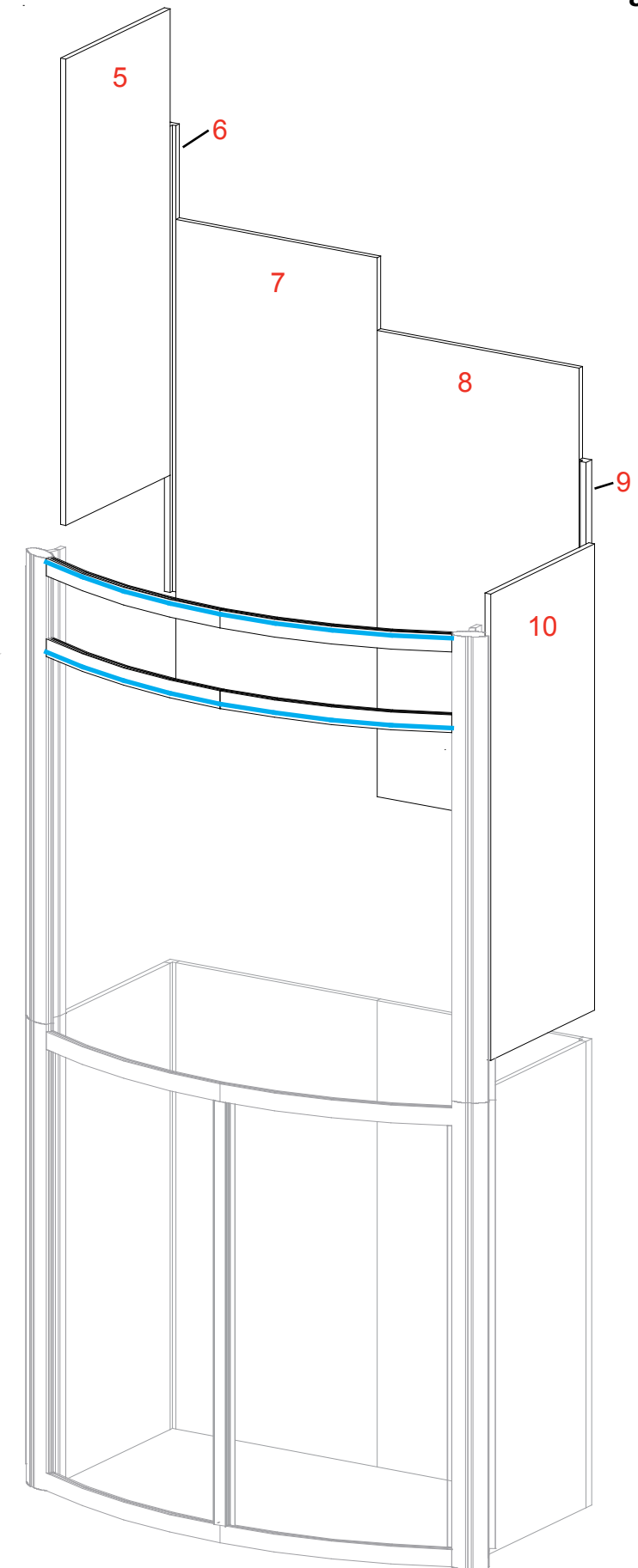
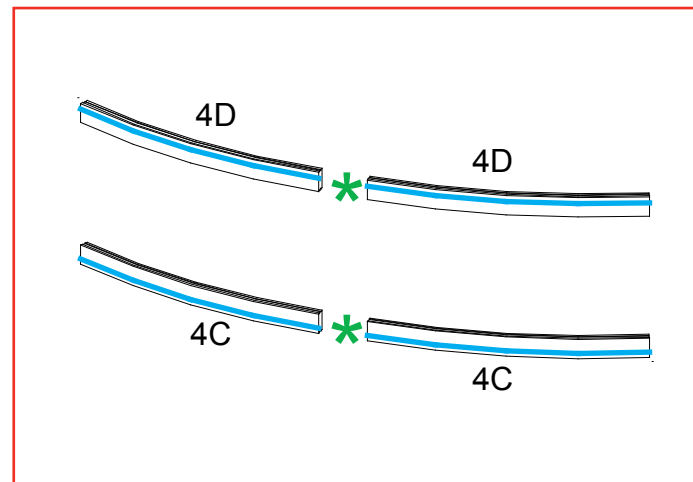

Steps:

- 1) Connect horizontal extrusions [4C] together.
See [Horizontal Connection](#) detail.
Repeat step for horizontals [4D].
- 2) Attach assembled horizontals between verticals [1A] & [2A].
- 3) Connect LT-Panels and LT-Connectors in numerical order. Refer to General Information.
- 4) Attach vertical [1A] to vertical [1].
See [Vertical Connector](#) detail.
Repeat step of vertical [2A].

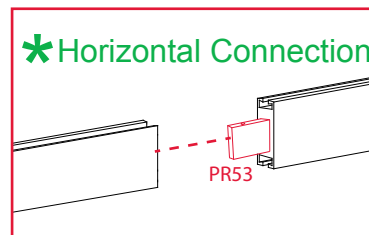

WHEN DISASSEMBLING ALUMINUM EXTRUSION, TIGHTEN ALL SETSCREWS AND LOCKS TO PREVENT LOSS DURING SHIPPING

Steps:

- 1) Connect **Shelf Supports** to interior of assembled tower.
- 2) Place internal shelf on top of installed shelf supports.
- 3) Insert counter top into tower and attach using thumb screws.
See **Counter Top Attachment** detail.
- 4) Hang assembled doors on hinges.
See **Door Attachment** detail.

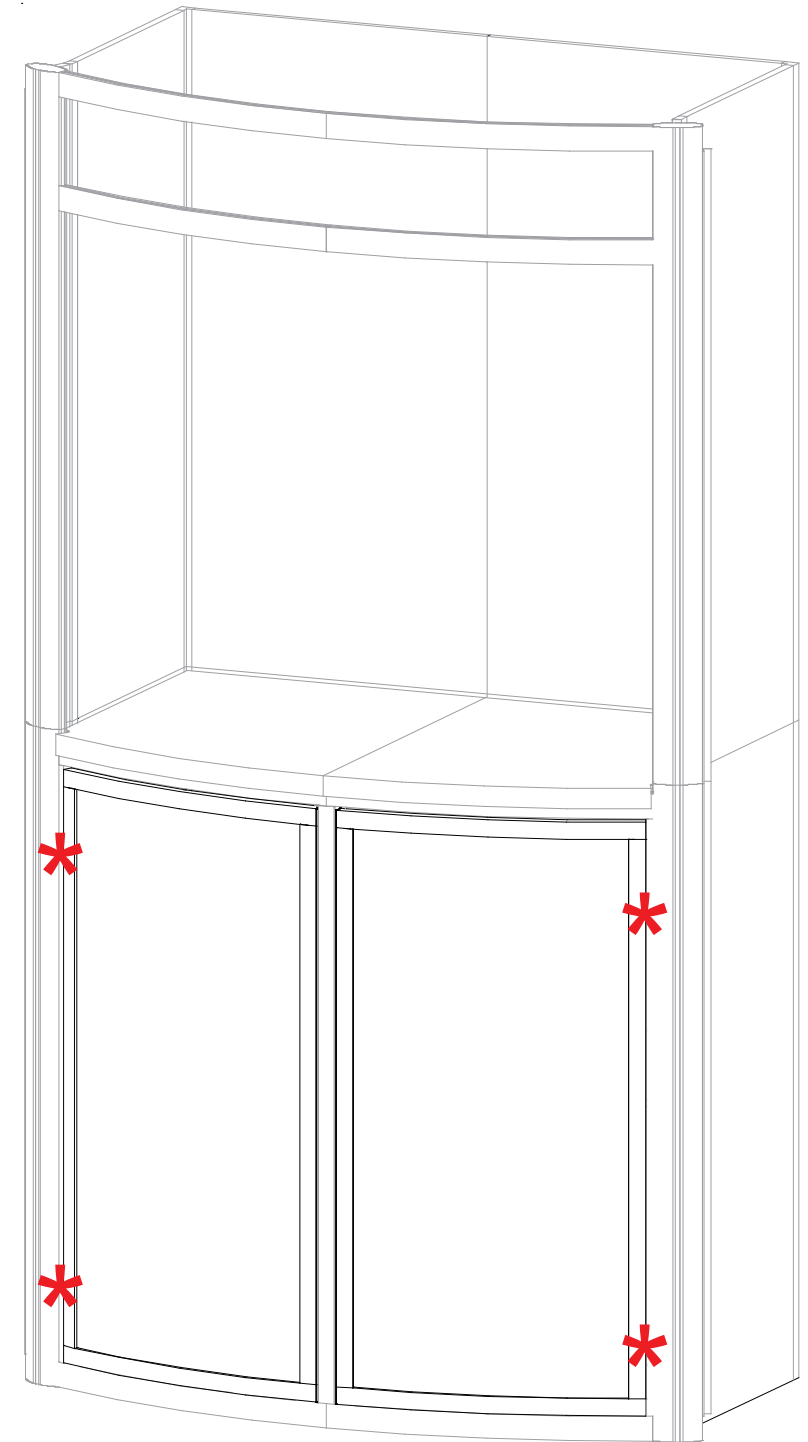
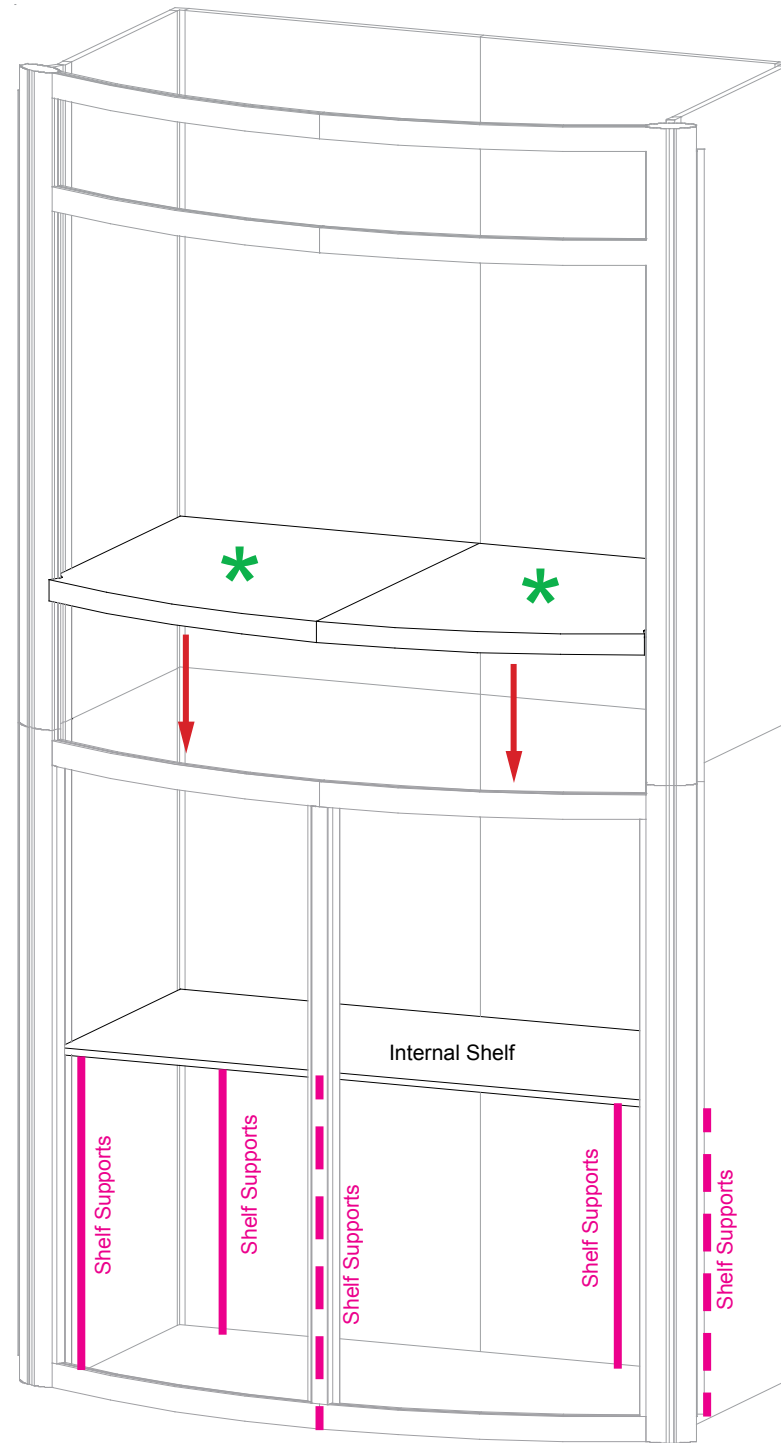
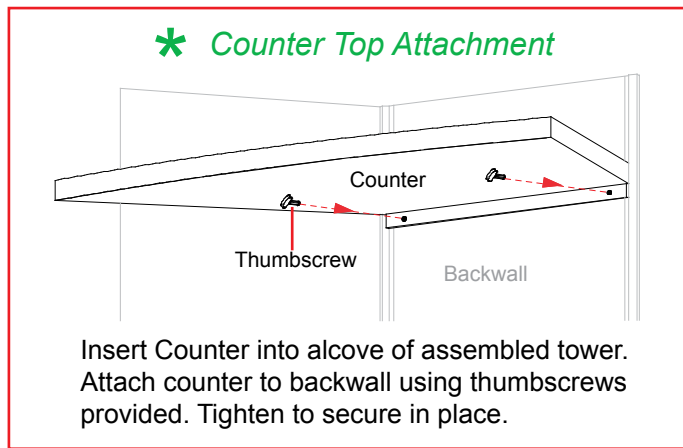

WHEN DISASSEMBLING ALUMINUM EXTRUSION, TIGHTEN ALL SETSCREWS AND LOCKS TO PREVENT LOSS DURING SHIPPING

| Item | Qty. | Description |
|--------|------|-------------------------------|
| 11/11A | 1/1 | 47.5”h Vertical Extrusion |
| 12/12A | 1/1 | 47.5”h Vertical Extrusion |
| 13/13A | 1/1 | 30”w Z45 Horizontal Extrusion |
| 14/14A | 1/1 | 30”w Z45 Horizontal Extrusion |

Steps:

- 1) Connect Vertical extrusions [11] & [11A] together.
See **Vertical Connector** detail.
Repeat step for horizontals [12] & [12A].
- 2) Attach horizontals [13] & [13A] between verticals [1/1A] & [11/11A].
- 3) Attach horizontals [14] & [14A] between verticals [2/2A] & [12/12A].
- 4) Apply Fabric graphics to back side of assembled frame.

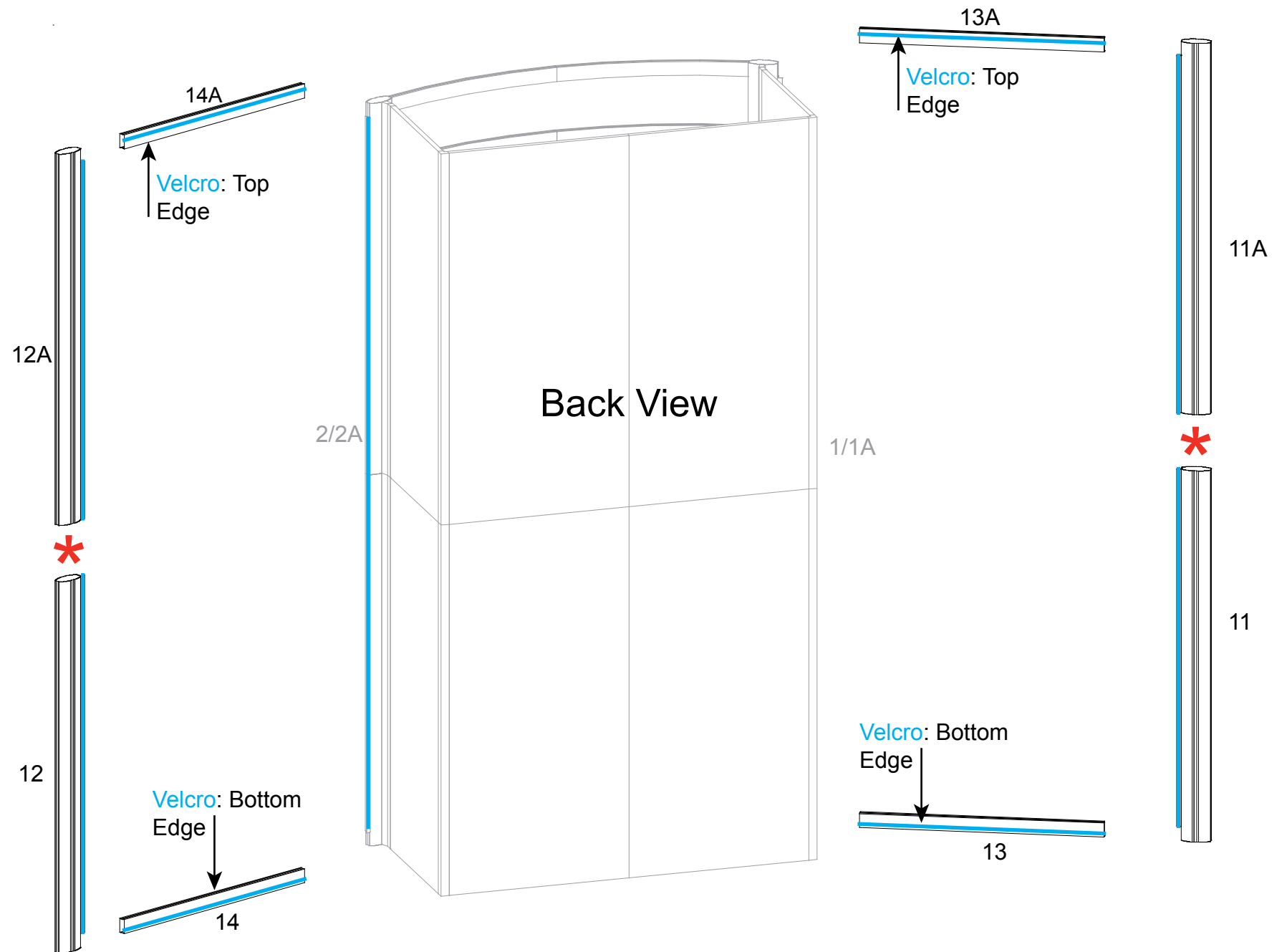
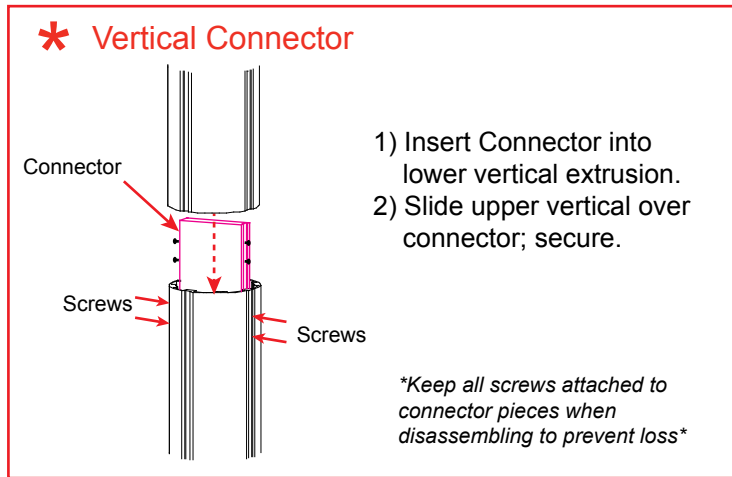

WHEN DISASSEMBLING ALUMINUM EXTRUSION, TIGHTEN ALL SETSCREWS AND LOCKS TO PREVENT LOSS DURING SHIPPING



866.652.2100

Using Your Setup Instructions

The Aero Overhead Sign Setup Instructions are created specifically for your configuration. They include an exploded view of the frame which is sequentially numbered. We encourage you to study the instructions before attempting to assemble your exhibit.

Connections are kept very simple: no tools. Everything assembles with push-button connectors and pre-connected horizontal sections.

Cleaning and Packing Your Display

- 1) Use care when cleaning aluminum extrusion or acrylic inserts. Use only non-abrasive cleaners.
- 2) Retain all packing material. It will make re-packing much easier and will reduce the likelihood of shipping damage.

Steps:

- 1) Assemble canopy in alphabetical order, matching letters.
- 2) Apply Pillowcase Graphic to assembled canopy.
- 3) Connect canopy to top of assembled backwall.

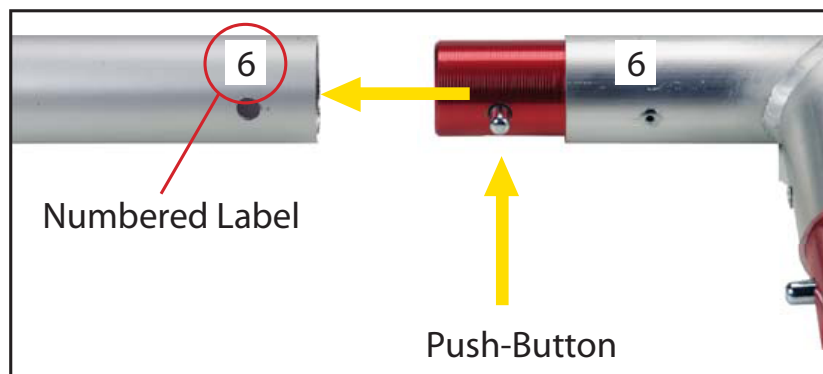

Connections are made by holding the button down and sliding the red tube into opposing tube until the connection is made. To disassemble push button and pull or twist extrusions apart.

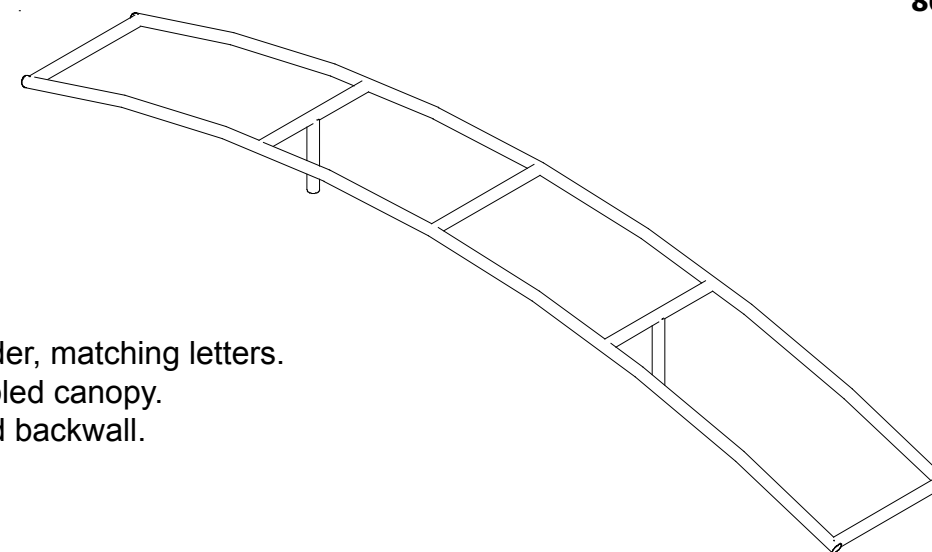
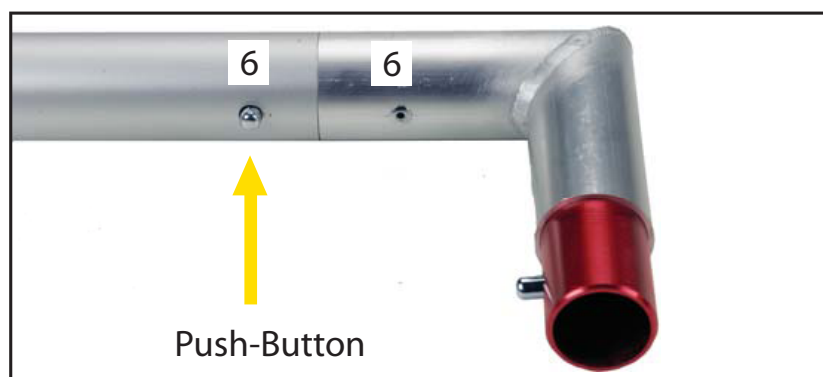

When assembled

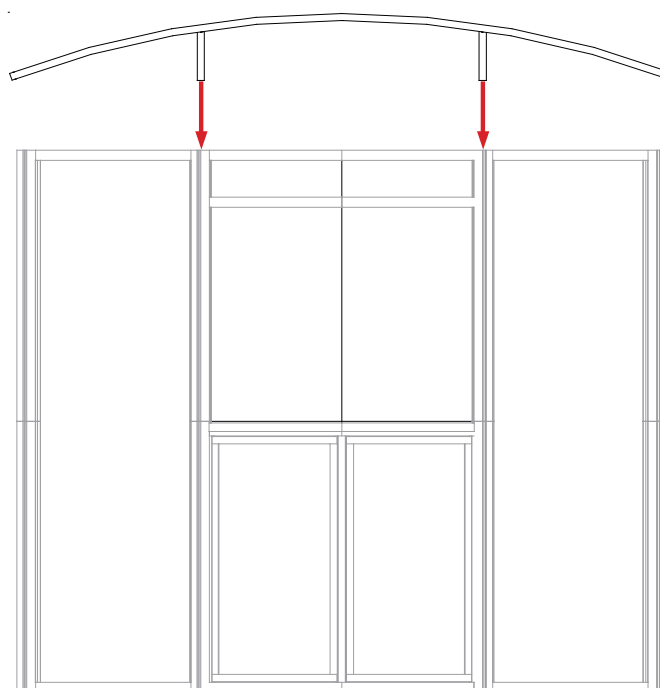
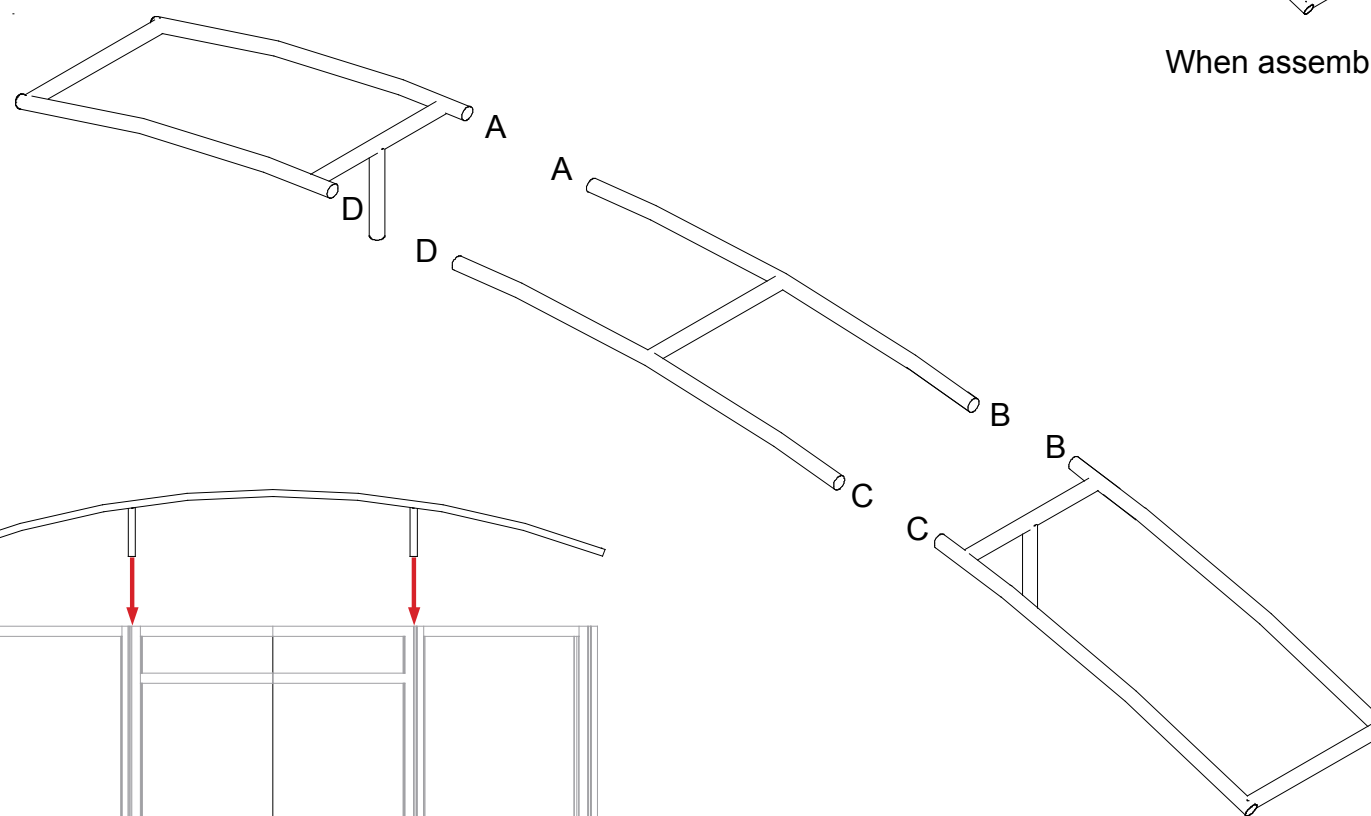

WHEN DISASSEMBLING ALUMINUM EXTRUSION, TIGHTEN ALL SETSCREWS AND LOCKS TO PREVENT LOSS DURING SHIPPING

866.652.2100

| Item | Qty | Description |
|------|-----|---------------------------------|
| 1 | 1 | 38" h Vertical Extrusion |
| 2 | 1 | 38" h Vertical Extrusion |
| 3 | 1 | 38" h Vertical Extrusion |
| 4 | 1 | 38" h Vertical Extrusion |
| 5 | 2 | 21.2810" w Horizontal Extrusion |
| 6 | 2 | 10.75" w Horizontal Extrusion |
| 7 | 2 | 21.2810" w Horizontal Extrusion |
| 8 | 2 | 10.75" w Horizontal Extrusion |

Steps:

- 1) Connect horizontal extrusions [5 and 6] between vertical extrusions [1, 2, 3 and 4] resting atop stoppers at approximately 4" up from floor to bottom of metal.
- 2) Set floor in place atop lip of horizontal extrusions.
- 3) Place doors and inserts in place as shown.
- 4) Connect horizontal extrusions [7, and 8] between vertical extrusions [1, 2, 3 and 4] and atop inserts and door.
- 5) Velcro shelf supports to inside of pedestal, then set internal shelf on top of supports.
- 6) Attach iPad to bottom of counter. Refer to detail.
- 7) Place counter top on assembled pedestal.

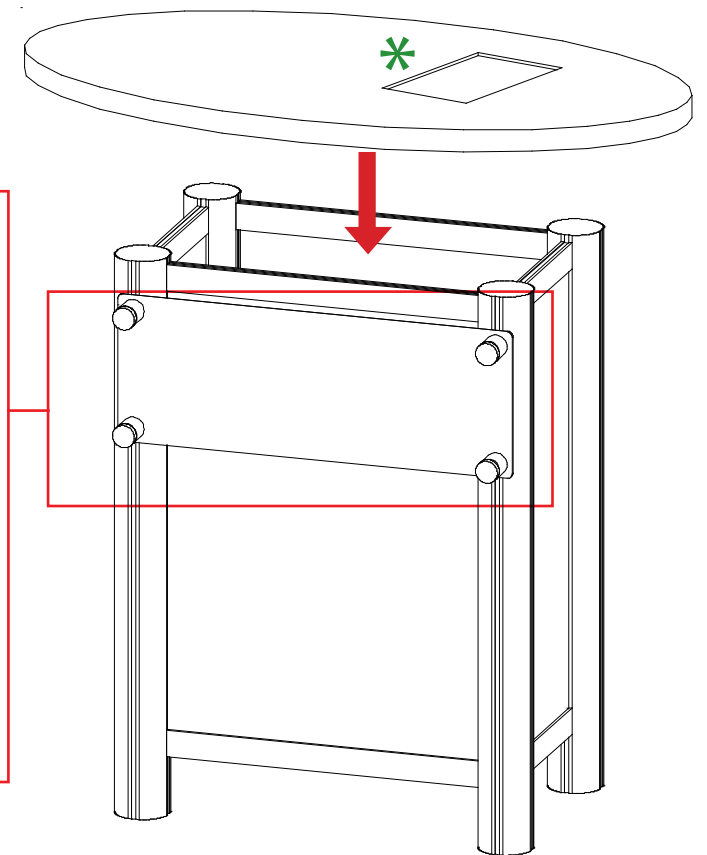
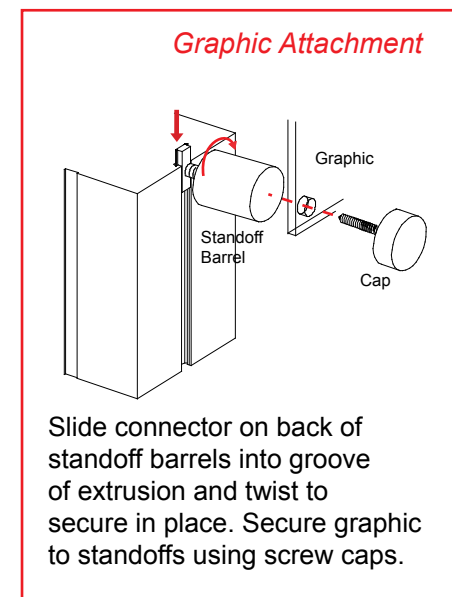
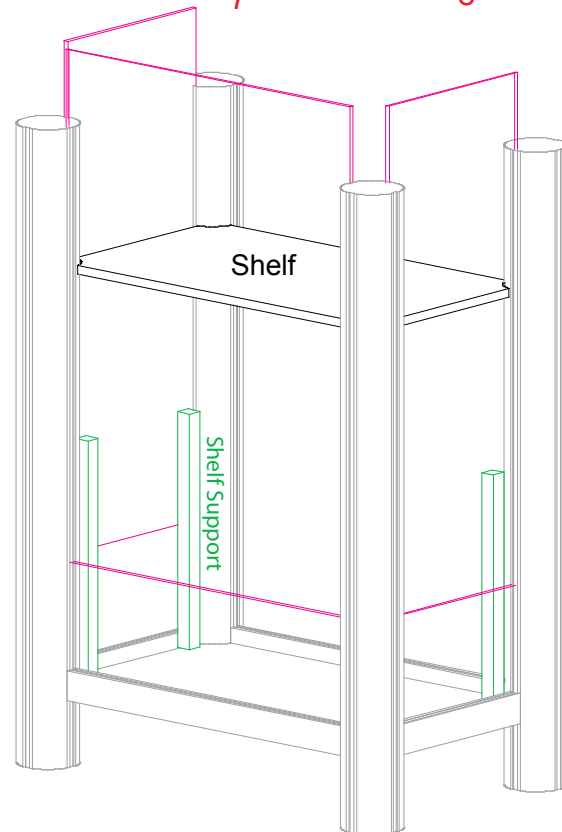
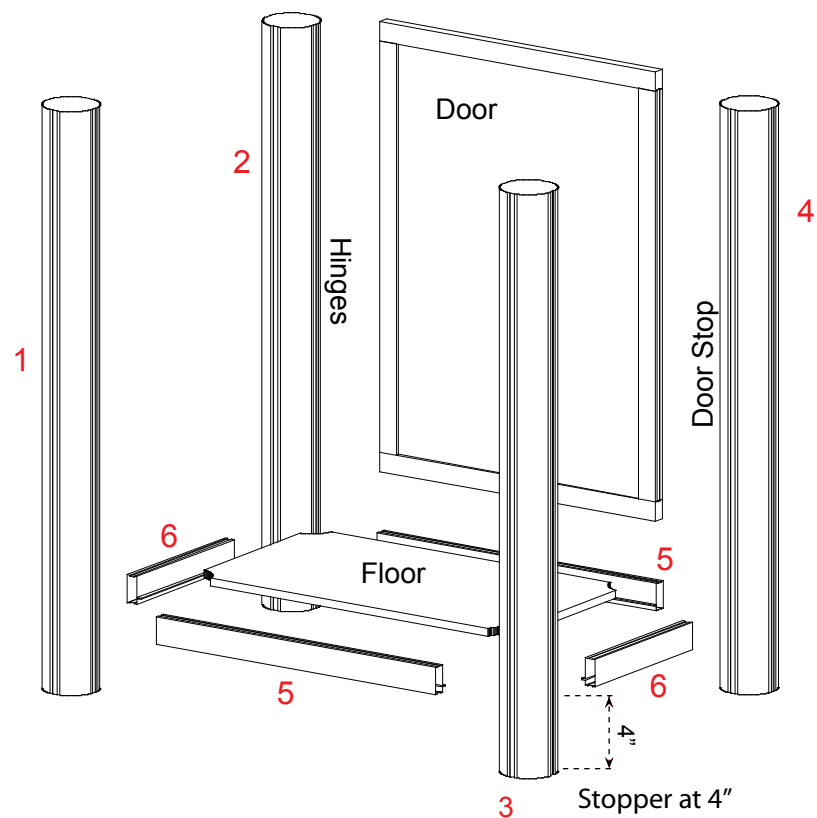
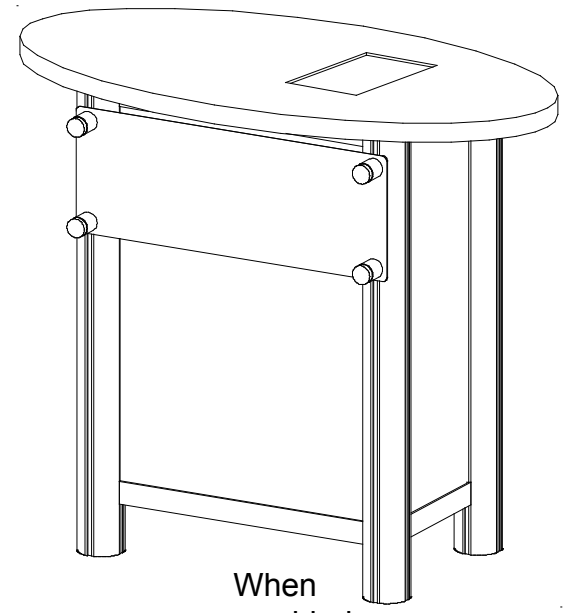
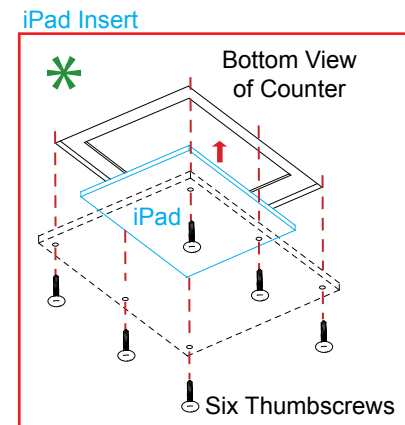
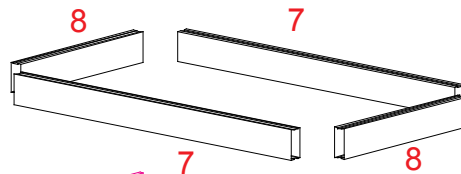
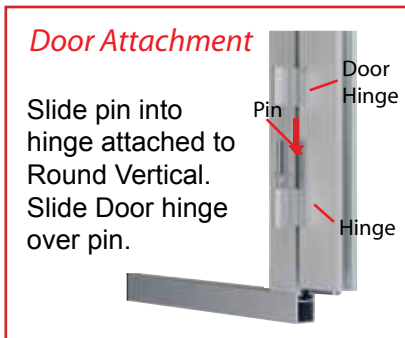

WHEN DISASSEMBLING ALUMINUM EXTRUSION, TIGHTEN ALL SETSCREWS AND LOCKS TO PREVENT LOSS DURING SHIPPING