

Item	Qty.	Description
1	1	26" x 26" x 3" Base
2	1	57.4675" RR91 Post
3	1	25" x 25" Counter Bottom
4,4A	3,1	6" Z45 Horizontal Extrusion
5	1	26" x 26" x 5" Counter Top
--	1	Bracket

Steps:

- 1) Attach base [1] to post [2], using bolt, routing power cord thru holes.
- 2) Slide counter bottom [3] over post [2]. **NOTE: Counter bottom will be "free floating" until counter top is attached.**
- 3) Connect extrusions [4,4A] to post [2]. **Note: Extrusion [4A] is permanently attached to underside of Counter Top.**
- 4) Slide counter top [5] over post [2], connect power cords to **USB ports & power outlets**, then attach to counter bottom [3] using bolts to **L-brackets**.
- 5) Install header to top of post [2], using bolt.
- 6) Connect transformer to lights in header. See **Light to Transformer Connection** detail and photos below.
- 7) Attach graphics to standoff barrels on front & back of header, using standoff caps.

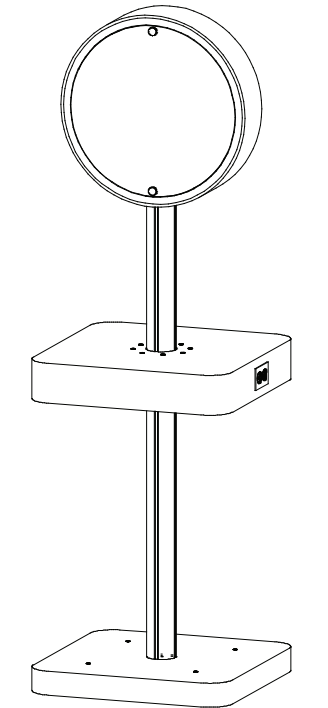
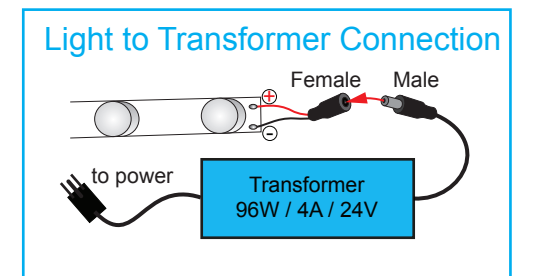
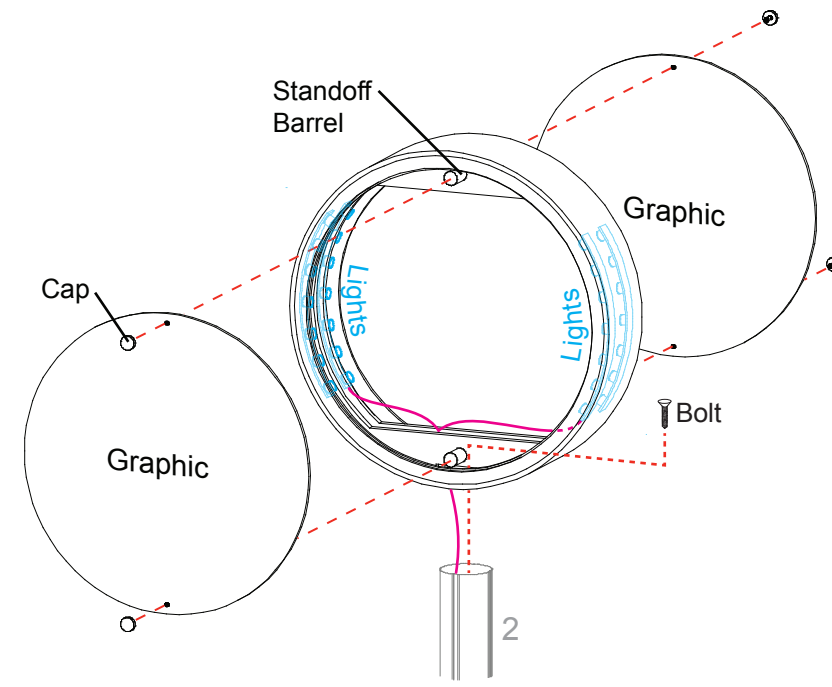
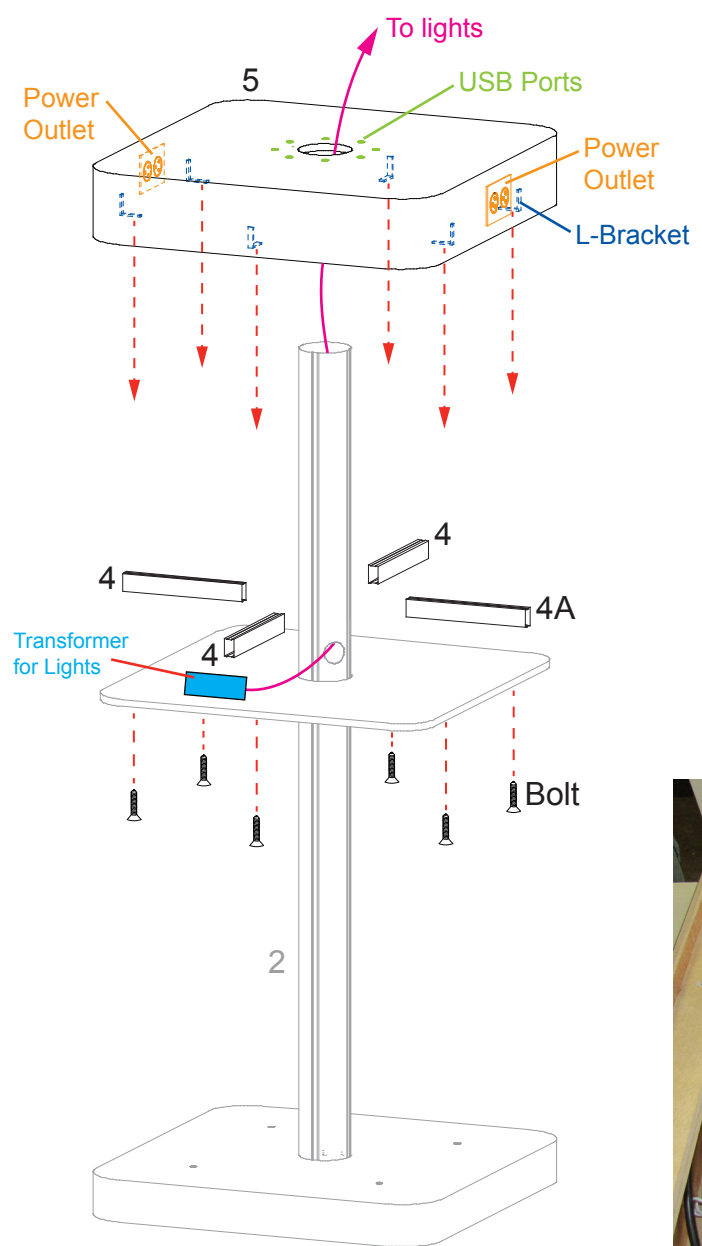
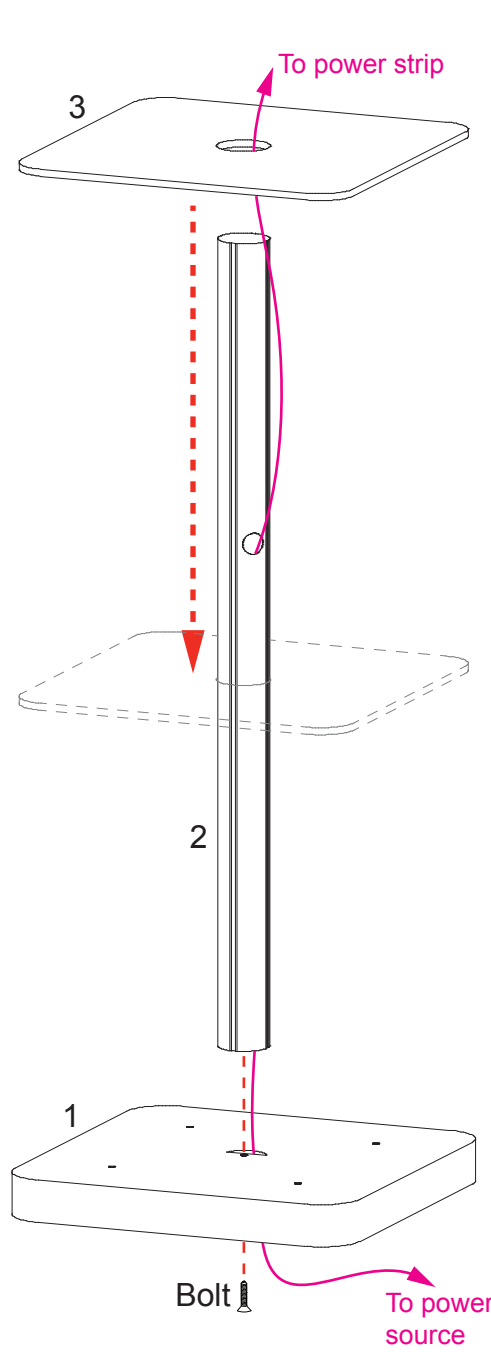

Completed Assembly

Underside View of Counter Top

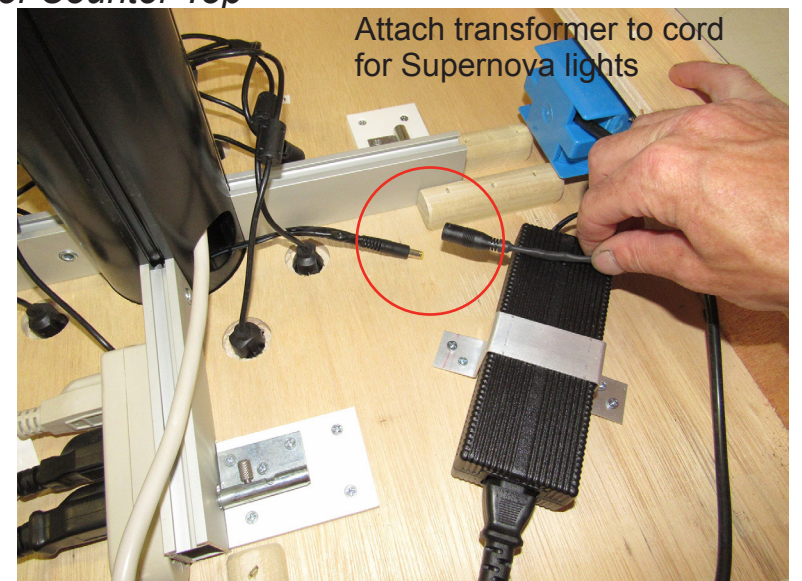
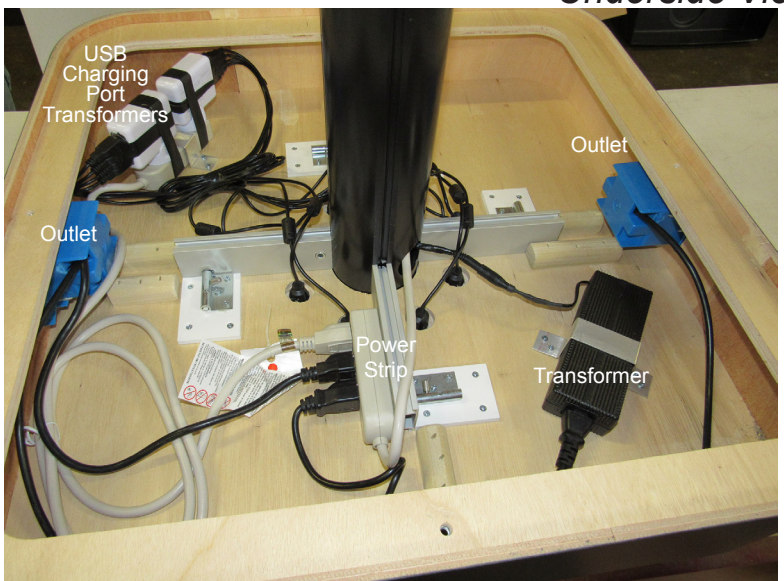

General Setup Instructions

- Read entire setup instruction manual prior to unpacking parts and pieces.
- The setup instructions are created specifically for this configuration.
- Setup instructions are laid out sequentially in steps, including exploded views with detailed explanation for assembly.

Cleaning & Packing

- For Cleaning Metal, Plex, & Laminate Parts: Use a **MILD NON-ABRASIVE** cleanser and soft cloth/paper towel to clean all surfaces.
- Keep exhibit components away from heat and prolonged sun exposure.
Heat and UV exposure will warp and fade components.
- Retain all provided Packing Materials. All provided packing materials are for ease of repacking & component protection.

Disassembly

- For loss prevention, tighten all setscrews and locks during disassembly

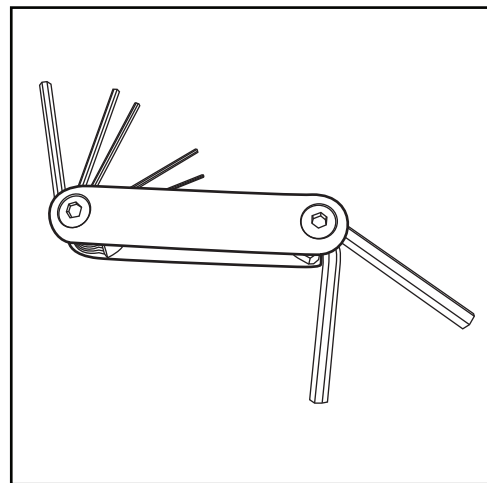

Hex Tool - Essential for Assembly

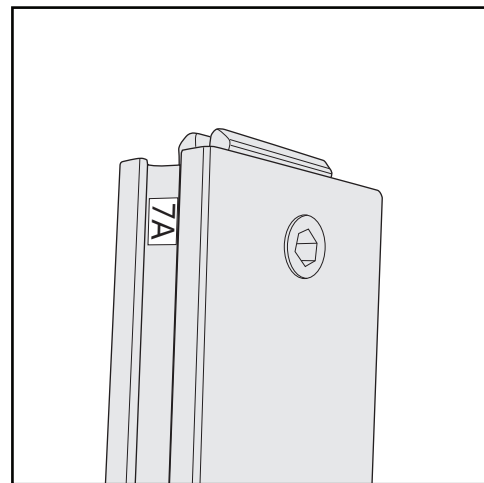

Part Identification - Numbering

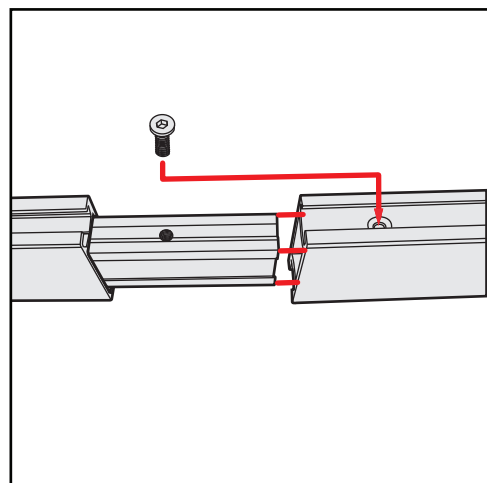

Spline Connection

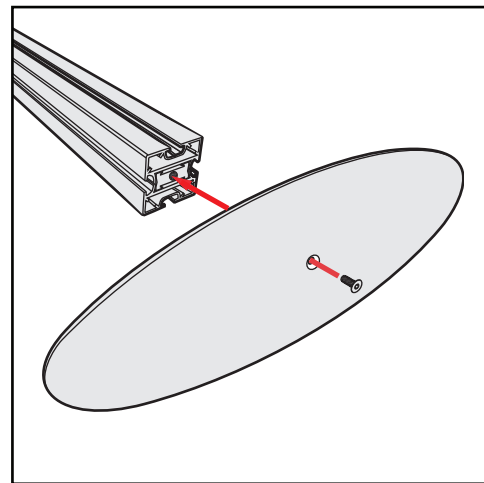

Base Plate & Extrusion Connection

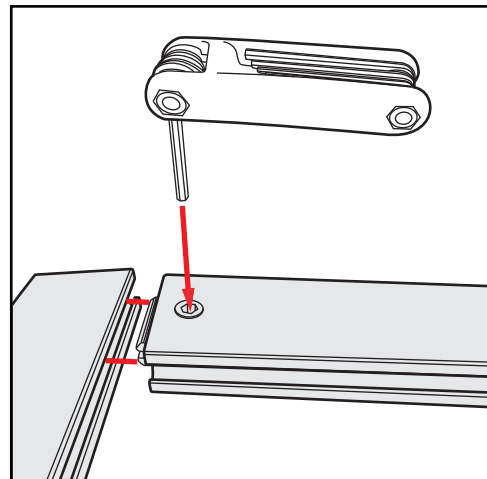

Extrusion & Lock Connection

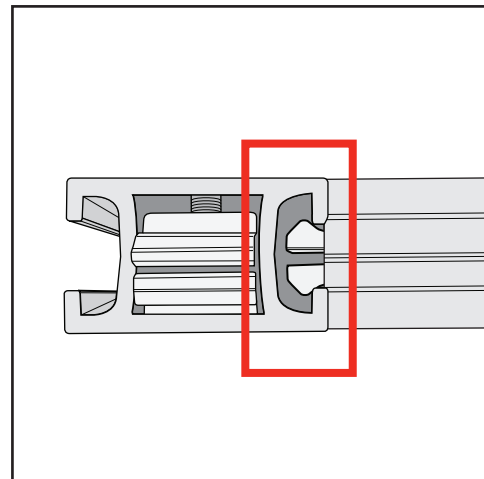

Engaged Lock



WARNING



DO NOT USE POWER TOOLS



LADDERS OR LIFTS
MAY BE REQUIRED



ALL CONNECTIONS MUST
BE TIGHTLY SECURED

Top View of Each Level

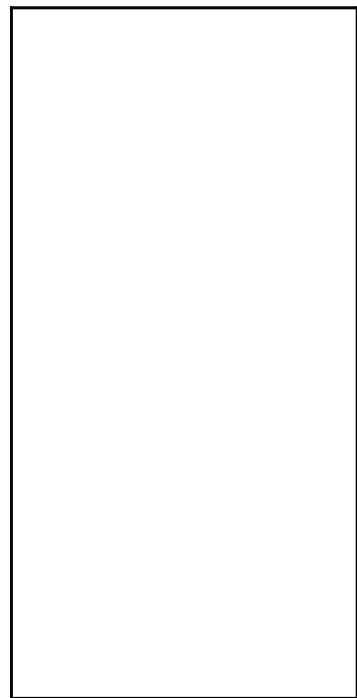

Level 1



Level 2



Level 3

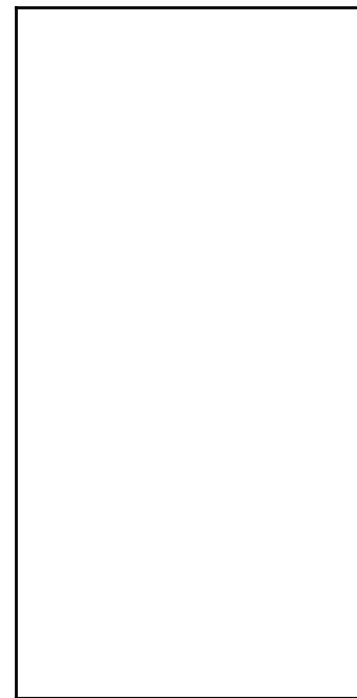

Level 4

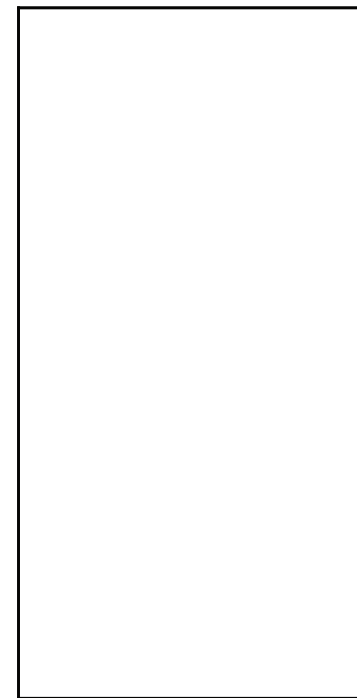

Level 5



Lights

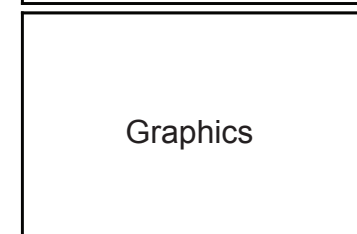

Graphics

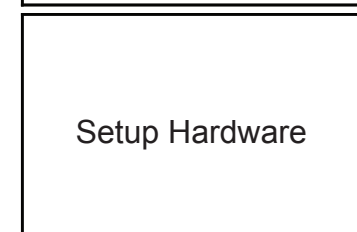

Setup Hardware

